



work • space • o • lo • gy™

VOLUME 28

about

ESI Ergonomic Solutions is a leading producer of ergonomic work tools that enhance productivity and wellness. ESI is known in the industry for its award-winning Customer Service and high quality products that are shipped in 48 hours. ESI's full line of ergonomic solutions includes monitor arms, height adjustable tables, lighting, keyboard solutions, technology solutions, and accessories. ESI is a Nationally Certified Woman-Owned business headquartered in Mesa, AZ.



FACTORY & SHOWROOM
4030 EAST QUENTON DRIVE
MESA, ARIZONA 85215

CHICAGO SHOWROOM
MERCHANDISE MART
SHOWROOM 10-100
CHICAGO, ILLINOIS 60654

CHICAGO SHOWROOM

The ESI Chicago showroom is located on the tenth floor, 10-100, of the Merchandise Mart.

OPTIONS FOR COLLABORATIVE SPACES

ESI features the EVOLVE4-FMS, a monitor arm configuration that provides dual monitors for two facing workstations.

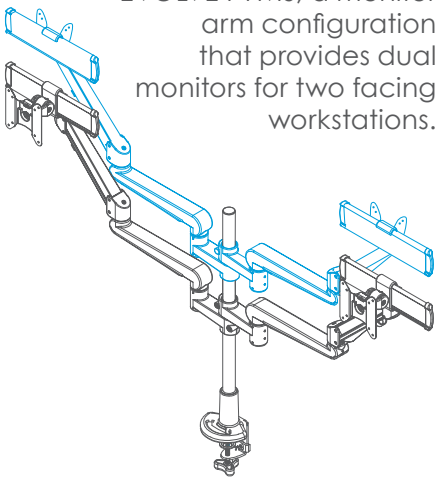

EVOLVE4-FMS
Get creative with the flexibility of the EVOLVE Series.

sit. stand. be well

We are flexible
We are flexible
We are flexible



work·space·o·lo·gy

the study of workplace design, form and function

STANDING ROOM

ESI's height adjustable table collection has a solution for virtually any sit-to-stand need including workstations, conference rooms, breakout rooms, and collaborative spaces.

ORDERING INFORMATION

Please e-mail your orders to orders@esiergo.com

CUSTOMER SERVICE

Toll Free: 800.833.3746
customerservice@esiergo.com

LIVE CHAT

esiergo.com



AWARD WINNING CUSTOMER SERVICE

If you need assistance, please call us! We are happy to help answer your questions or provide product recommendations.

48 HOUR SHIPPING

Most catalog products ship in 48 hours with the exception of those designated

as  **LLT** Longer Lead Time

ESTIMATED TRANSIT TIMES

FROM MESA, ARIZONA

- 1 DAY (purple square)
- 2 DAYS (blue square)
- 3 DAYS (orange square)
- 4 DAYS (green square)
- 5 DAYS (red square)
- 6 DAYS (dark blue square)
- 7+ DAYS (light blue square)

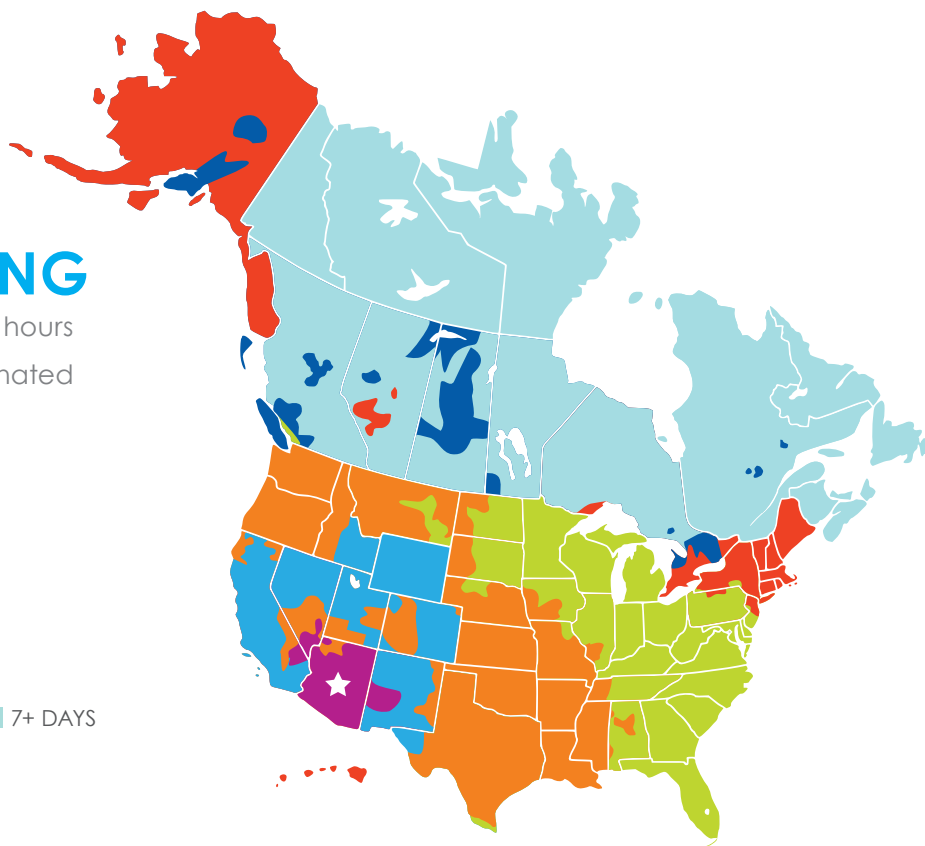

Contract Holder

Most ESI products are on GSA and available with contract pricing. Those products not available through GSA are designated as 

CONTRACT: GS-28F-0028Y
CAGE CODE: 1CTH6
DUNS#: 874792500
FEDERAL TAX ID#: 86-0955047
FSC GROUP: 71 Part 1 Office Furniture

FSC CLASS:
711-2 (Work Surfaces, Workstations, Computer Furniture & Accessories)
711-95 (Office Furniture Installation Services)



MONITOR ARMS

- 6** EDGE Series
- 7** Laptop Solutions
- 10** EVOLVE Series
- 14** EDGE-MAX Series
- 15** Accessories



TABLES

- 19** TRIUMPH
- 20** VICTORY
- 22** PREMIUM
- 26** Q-CRANK
- 27** ESPREE
- 28** CORE
- 29** Work Surfaces

- 24** work•space•o•lo•gy™



TECHNOLOGY SOLUTIONS

- 31** ERGORISE LIFT
- 33** ERGORISE CLIMB
- 34** TITAN Series
- 35** WOW Series
- 36** CPU Holders



LIGHTING

- 37** Under Cabinet Lighting
- 38** Desktop Task Lighting



KEYBOARD SOLUTIONS

- 41** Combo Solutions
- 44** Keyboard Platforms
- 45** Articulating Arms



ACCESSORIES

- 46** Accessories

- 48** Terms and Conditions



FREE DOWNLOAD

Download this year's catalog on your iPad or iPhone from the iBOOKS store to access additional pictures, videos, 3D models and more!

All ESI monitor arms include both a desk clamp and grommet mount giving you freedom to choose during installation.

EDGE

SINGLE MONITOR ARM
DYNAMIC HEIGHT ADJUSTMENT

PART #	LIST PRICE
● EDGE-SLV	\$341
● EDGE-BLK	\$341
○ EDGE-WHT	\$341

- Height Adjustment Range: 13"
 - LOW: 7" | HIGH: 20"
- Monitor Extension: 22.5"
- Monitor Tilt: +25°/-90°
- Monitor Rotation: +90°/-90°
- Weight Capacity (per arm):
 - Minimum: 6.5 lbs
 - Maximum: 17.6 lbs
- 180° Lock-Out Feature
- Quick Release



EDGE2KIT

CONVERSION KIT

Converts an existing EDGE single monitor arm to an EDGE2 dual arm

PART #	LIST PRICE
● EDGE2KIT-SLV	\$343



EDGE2

DUAL MONITOR ARM
DYNAMIC HEIGHT ADJUSTMENT

PART #	LIST PRICE
● EDGE2-SLV	\$632
● EDGE2-BLK	\$632
○ EDGE2-WHT	\$632

- Height Adjustment Range: 13"
 - LOW: 7" | HIGH: 20"
- Monitor Extension: 22.5"
- Monitor Tilt +25°/-90°
- Monitor Rotation +90°/-90°
- Weight Capacity (per arm):
 - Minimum: 6.5 lbs | Maximum: 17.6 lbs
- 180° Lock-Out Feature
- Quick Release
- Max Monitor Width: 28" (bezel measured left to right)

EDGE2-MS

DUAL MONITOR ARM
DYNAMIC HEIGHT ADJUSTMENT

PART #	LIST PRICE
● EDGE2-MS-SLV	\$632
● EDGE2-MS-BLK	\$632
○ EDGE2-MS-WHT	\$632

- Height Adjustment Range: 13"
- Monitor Extension: 17"
- Monitor Tilt +25°/-90°
- Monitor Rotation +90°/-90°
- Sliders provide 9" of additional horizontal adjustability
- Weight Capacity (per arm):
 - Minimum: 4.4 lbs | Maximum: 15.4 lbs
- 180° Lock-Out Feature
- Quick Release
- Max Monitor Width: 28" (bezel measured left to right)

DEEP WORK SURFACES

The EDGE2 provides extended reach over a deep work surface.



SHALLOW WORK SURFACES

The EDGE2-MS is ideal for shallow work surfaces that are 24" deep or less.

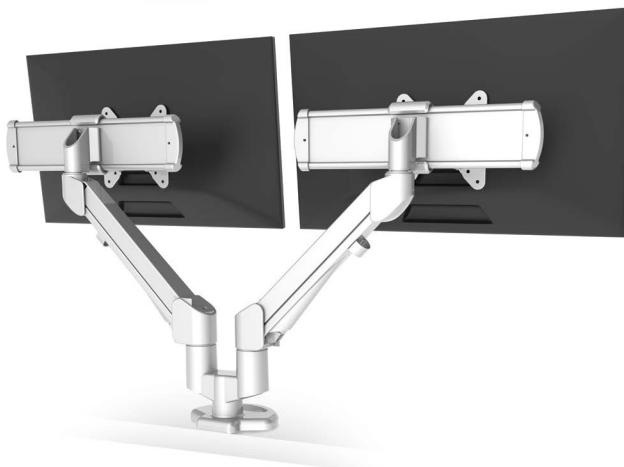



EDGE2-MS

DUAL MONITOR ARM

SPIN ME

Take your monitor from landscape to portrait orientation with a quick turn. Monitors cannot rotate beyond portrait orientation, preventing cables from detaching from the monitor.

EDGE2COMBO

EDGE ARM WITH ADJUSTABLE LAPTOP TRAY

DYNAMIC HEIGHT ADJUSTMENT

Laptop tray is 10.25" in width and adjusts from 12"-18.25" in depth to accommodate laptop alone or laptop with docking station.

PART #

LIST PRICE

● **EDGE2COMBO-SLV**

\$796

LTH-EDGE

LAPTOP TRAY

• Can be added to any existing EDGE or EVOLVE monitor arm

PART #

LIST PRICE

● **LTH-EDGE-SLV**

\$175

MONITOR ARM NOT INCLUDED



ADAPTABLE

Convert your existing EDGE or EVOLVE monitor arm with the LTH-EDGE.



Extended



Retracted



Laptop Closed



Laptop Open

WHAT TO CONSIDER WHEN SELECTING A MONITOR ARM

NUMBER OF MONITORS

ESI offers solutions for as few as one to as many as six monitors. Should the needs of the user change, the EVOLVE series can easily be modified in the field to accommodate additional monitors and changing work environments.

HEIGHT ADJUSTMENT

Monitor arms offer various types of height adjustability. The most user-friendly option is dynamic height adjustment which allows the user to adjust the monitor height quickly and easily without the need for tools.

WEIGHT OF MONITOR(S)

ESI's standard monitor arm configurations support the average monitor which weighs between 8-16 lbs. For heavier monitors such as Apple Cinema Displays®, iMacs® and the new VESA-compatible all-in-one PC's, ESI recommends the EDGE-MAX series.

SIZE OF MONITOR(S)

Most users prefer to have their monitors side-by-side as close as possible with no gap between them. The versatility of the ESI EVOLVE series allows up to 32" monitors to fit side-by-side. Configurations that include a SLIDER will provide additional horizontal adjustability, allowing monitors of varying sizes to fit together seamlessly.

SIZE AND SHAPE OF THE WORK SURFACE

Shallow work surface depths 24" or less are best suited for monitor arm configurations with fewer limbs. For applications that require extended reach, ESI recommends an EVOLVE configuration with the maximum number of limbs. When positioning two or more monitors side-by-side in a 90° corner, the maximum monitor size will be reduced. Customer Service representatives are available to discuss your specific application and requirements.

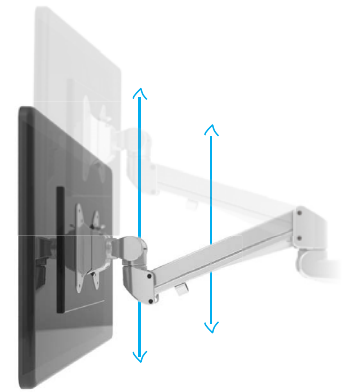

Motion arms move your monitor straight up and down.

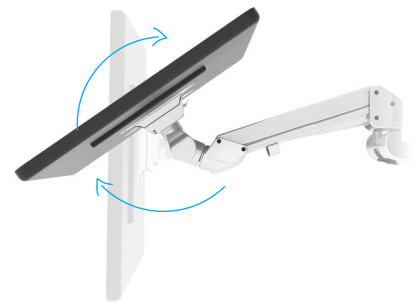

VESA mounts tilt up and down, providing a flat writing surface for touch screen monitors.

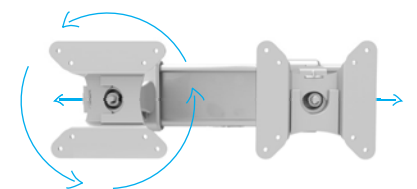

Sliders move your monitor left and right while retaining monitor tilt and +90°/-90° monitor rotation.



GROW. ADAPT. EVOLVE.

As technology advances and monitors are becoming lighter and wider, challenges are created in workstation design. The EVOLVE allows the merger of form and function with one product that will easily adapt to the fluidly changing needs of today's workplace. Whether you have a shallow or deep work surface, 1, 2, 3 or more monitors, the EVOLVE can adapt to fit your needs.

STANDARD EVOLVE CONFIGURATIONS SHOWN ON PAGES 10-13

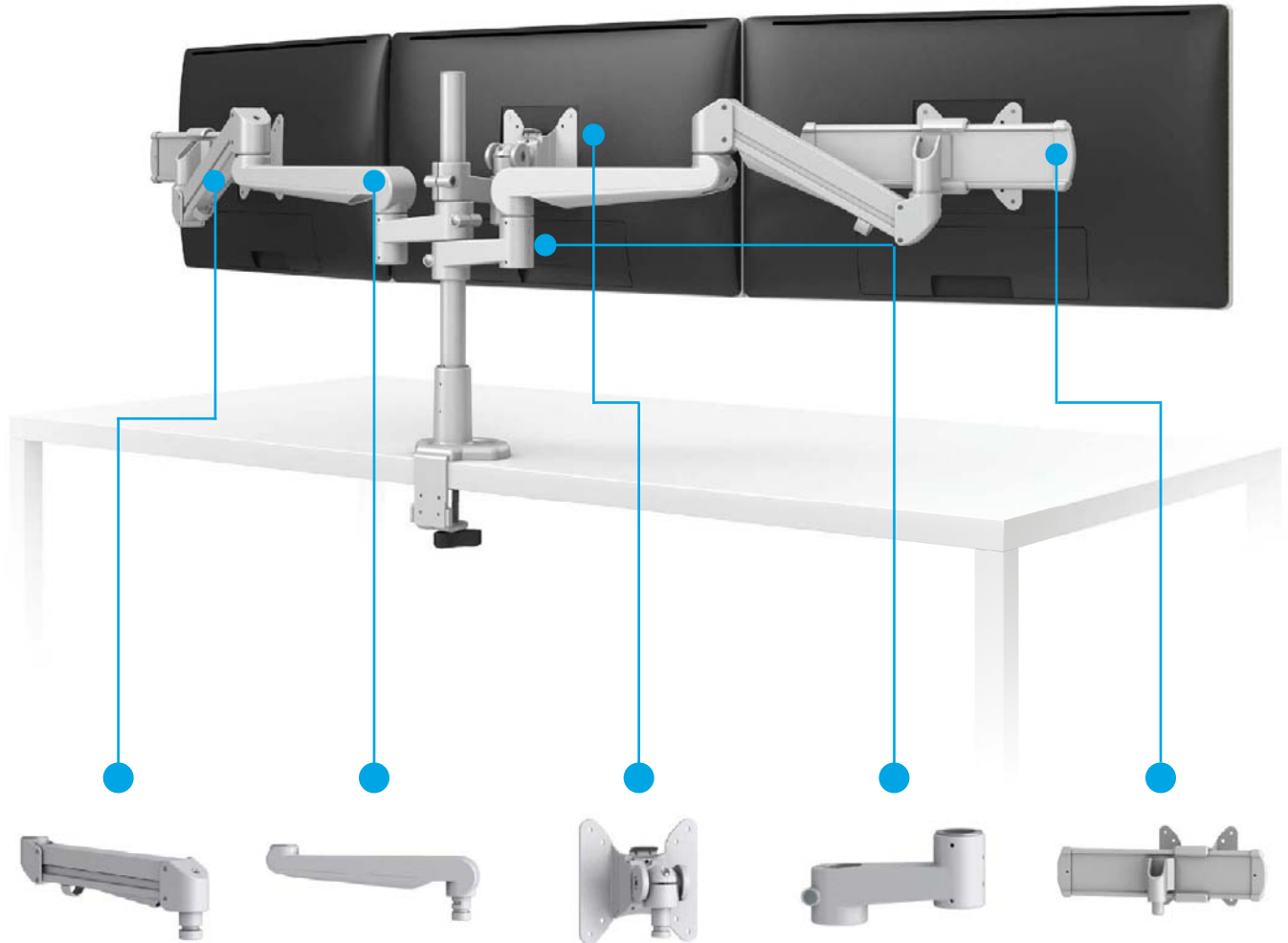

(M) MOTION
MOTION ARM

Motion arms provide 13" of dynamic height adjustment.

(F) FIXED
STRAIGHT ARM

Fixed arms provide extra reach.

VESA MOUNT
MONITOR ATTACHMENT

A VESA Mount attaches your monitor to the arm.

ARM STEM
STRAIGHT ARM

Arm Stems are included in every configuration.

(S) SLIDER MOUNT
VESA SLIDER

Sliders provide extended lateral adjustment - ideal for positioning monitors of varying sizes side-by-side.

EVOLVE1-M

MOTION
DYNAMIC HEIGHT ADJUSTMENT

- Monitor Extension: 16.25"
- Monitor Tilt: +25°/-90°
- Monitor Rotation: +90°/-90°
- Weight Capacity (per arm):
 - Minimum: 6.5 lbs
 - Maximum: 17.6 lbs
- 180° Lock-Out Feature
- Quick Release
- 16" Pole

PART #	LIST PRICE
EVOLVE1-M-SLV	\$372



EVOLVE-STUBBY

SHORT ARM
MANUAL HEIGHT ADJUSTMENT

- Monitor Extension: 6"
- Monitor Tilt: +25°/-90°
- Monitor Rotation: +90°/-90°
- Weight Capacity (per arm):
 - Minimum: N/A
 - Maximum: 20 lbs
- 180° Lock-Out Feature
- Quick Release
- 16" Pole

PART #	LIST PRICE
EVOLVE-STUBBY-SLV	\$242



EVOLVE1-F

FIXED
MANUAL HEIGHT ADJUSTMENT

- Monitor Extension: 16.25"
- Monitor Tilt: +25°/-90°
- Monitor Rotation: +90°/-90°
- Weight Capacity (per arm):
 - Minimum: N/A
 - Maximum: 20 lbs
- 180° Lock-Out Feature
- Quick Release
- 16" Pole

PART #	LIST PRICE
EVOLVE1-F-SLV	\$294



EVOLVE1-FF

FIXED + FIXED
MANUAL HEIGHT ADJUSTMENT

- Monitor Extension: 26.75"
- Monitor Tilt: +25°/-90°
- Monitor Rotation: +90°/-90°
- Weight Capacity (per arm):
 - Minimum: N/A
 - Maximum: 20 lbs
- 180° Lock-Out Feature
- Quick Release
- 16" Pole

PART #	LIST PRICE
EVOLVE1-FF-SLV	\$346



EVOLVE1-FM

FIXED + MOTION
DYNAMIC HEIGHT ADJUSTMENT

- Monitor Extension: 26.75"
- Monitor Tilt: +25°/-90°
- Monitor Rotation: +90°/-90°
- Weight Capacity (per arm):
 - Minimum: 6.5 lbs
 - Maximum: 17.6 lbs
- 180° Lock-Out Feature
- Quick Release
- 16" Pole

PART #	LIST PRICE
EVOLVE1-FM-SLV	\$424



EVOLVE2-FF

FIXED + FIXED
MANUAL HEIGHT ADJUSTMENT

- Monitor Extension: 26.75"
- Monitor Tilt: +25°/-90°
- Monitor Rotation: +90°/-90°
- Weight Capacity (per arm):
 - Minimum: N/A
 - Maximum: 20 lbs
- 180° Lock-Out Feature
- Quick Release
- 16" Pole
- Max Monitor Width: 27" (bezel measured left to right)

PART #	LIST PRICE
EVOLVE2-FF-SLV	\$577



EVOLVE2-FM

FIXED + MOTION
DYNAMIC HEIGHT ADJUSTMENT

- Monitor Extension: 26.75"
- Monitor Tilt: +25°/-90°
- Monitor Rotation: +90°/-90°
- Weight Capacity (per arm):
 - Minimum: 6.5 lbs
 - Maximum: 17.6 lbs
- 180° Lock-Out Feature
- Quick Release
- 16" Pole
- Max Monitor Width: 27" (bezel measured left to right)

PART #	LIST PRICE
EVOLVE2-FM-SLV	\$733



EVOLVE2-FS

FIXED + SLIDER
MANUAL HEIGHT ADJUSTMENT

- Monitor Extension: 16.25"
- Monitor Tilt: +60°/-80°
- Monitor Rotation: +90°/-90°
- Weight Capacity (per arm):
 - Minimum: N/A
 - Maximum: 20 lbs
- 180° Lock-Out Feature
- Quick Release
- 16" Pole
- Max Monitor Width: 27" (bezel measured left to right)

PART #	LIST PRICE
EVOLVE2-FS-SLV	\$589



EVOLVE2-FMS

FIXED + MOTION + SLIDER
DYNAMIC HEIGHT ADJUSTMENT

- Monitor Extension: 28.75"
- Monitor Tilt: +60°/-80°
- Monitor Rotation: +90°/-90°
- Weight Capacity (per arm):
 - Minimum: 4.4 lbs
 - Maximum: 15.4 lbs
- 180° Lock-Out Feature
- Quick Release
- 16" Pole
- Max Monitor Width: 32" (bezel measured left to right)

PART #	LIST PRICE
EVOLVE2-FMS-SLV	\$849



EVOLVE2-MS

MOTION + SLIDER
DYNAMIC HEIGHT ADJUSTMENT

- Monitor Extension: 16.25"
- Monitor Tilt: +60°/-80°
- Monitor Rotation: +90°/-90°
- Weight Capacity (per arm):
 - Minimum: 4.4 lbs
 - Maximum: 15.4 lbs
- 180° Lock-Out Feature
- Quick Release
- 16" Pole
- Max Monitor Width: 27" (bezel measured left to right)

PART #	LIST PRICE
EVOLVE2-MS-SLV	\$745

EFFORTLESS ALIGNMENT

Easily align large monitors of varying sizes side-by-side with a slider.



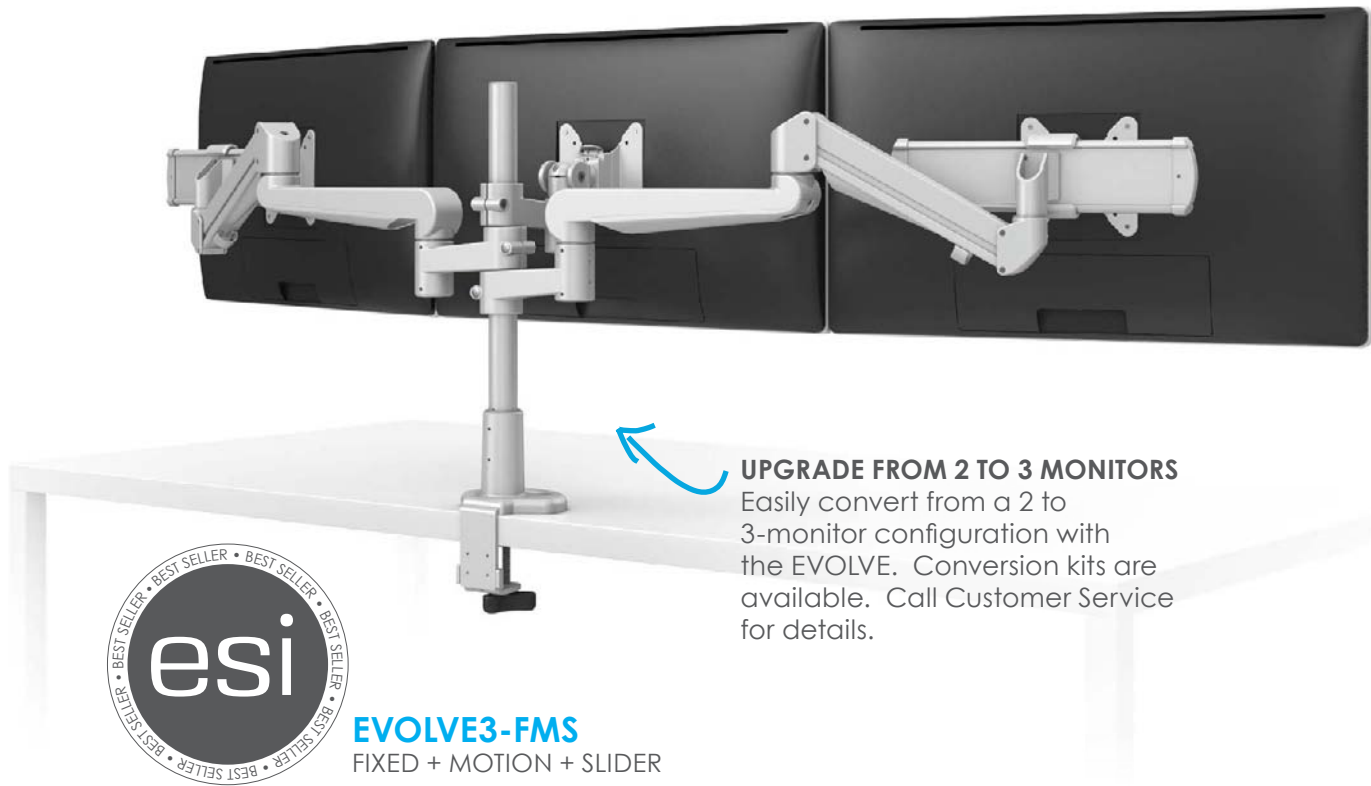

UPGRADE FROM 2 TO 3 MONITORS

Easily convert from a 2 to 3-monitor configuration with the EVOLVE. Conversion kits are available. Call Customer Service for details.



EVOLVE3-FMS
FIXED + MOTION + SLIDER

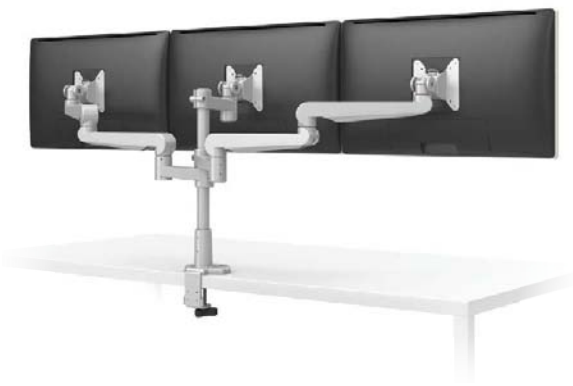

EVOLVE3-FF

FIXED + FIXED
MANUAL HEIGHT ADJUSTMENT

- Outside Monitor Extension: 28.75"
- Center Monitor Extension: 6"
- Monitor Tilt: +25°/-90°
- Monitor Rotation: +90°/-90°
- Quick Release
- 16" Pole
- Weight Capacity (per arm):
 - Minimum: N/A
 - Maximum: 20 lbs
- 180° Lock-Out Feature
- Max Monitor Width: 21.5" (bezel measured left to right)

PART #

LIST PRICE

● **EVOLVE3-FF-SLV**

\$704



EVOLVE3-FMS

FIXED + MOTION + SLIDER
DYNAMIC HEIGHT ADJUSTMENT

- Outside Monitor Extension: 28.75"
- Center Monitor Extension: 6"
- Monitor Tilt: +60°/-80°
- Monitor Rotation: +90°/-90°
- Quick Release
- 16" Pole
- Weight Capacity (per arm):
 - Minimum: 4.4 lbs
 - Maximum: 15.4 lbs
- 180° Lock-Out Feature
- Max Monitor Width: 32" (bezel measured left to right)

PART #

LIST PRICE

● **EVOLVE3-FMS-SLV**

\$976



EVOLVE4-FF

FIXED + FIXED
MANUAL HEIGHT ADJUSTMENT

- Monitor Extension: 26.75"
- Monitor Tilt: +25°/-90°
- Monitor Rotation: +90°/-90°
- Weight Capacity (per arm):
 - Minimum: N/A
 - Maximum: 20 lbs
- 180° Lock-Out Feature
- Quick Release
- 28" Pole
- Max Monitor Width: 27" (bezel measured left to right)

PART #	LIST PRICE
● EVOLVE4-FF-SLV	\$1,048



EVOLVE4-FM

FIXED + MOTION
DYNAMIC HEIGHT ADJUSTMENT

- Monitor Extension: 26.75"
- Monitor Tilt: +25°/-90°
- Monitor Rotation: +90°/-90°
- Weight Capacity (per arm):
 - Minimum: 6.5 lbs
 - Maximum: 17.6 lbs
- 180° Lock-Out Feature
- Quick Release
- 28" Pole
- Max Monitor Width: 27" (bezel measured left to right)

PART #	LIST PRICE
● EVOLVE4-FM-SLV	\$1,360



EVOLVE4-MS

MOTION + SLIDER
DYNAMIC HEIGHT ADJUSTMENT

- Monitor Extension: 18.75"
- Monitor Tilt: +60°/-80°
- Monitor Rotation: +90°/-90°
- Weight Capacity (per arm):
 - Minimum: 4.4 lbs
 - Maximum: 15.4 lbs
- 180° Lock-Out Feature
- Quick Release
- 28" Pole
- Max Monitor Width: 27" (bezel measured left to right)

PART #	LIST PRICE
● EVOLVE4-MS-SLV	\$1,384



EVOLVE4-FMS

FIXED + MOTION + SLIDER
DYNAMIC HEIGHT ADJUSTMENT

- Monitor Extension: 28.75"
- Monitor Tilt: +60°/-80°
- Monitor Rotation: +90°/-90°
- Weight Capacity (per arm):
 - Minimum: 4.4 lbs
 - Maximum: 15.4 lbs
- 180° Lock-Out Feature
- Quick Release
- 28" Pole
- Max Monitor Width: 32" (bezel measured left to right)

PART #	LIST PRICE
● EVOLVE4-FMS-SLV	\$1,592

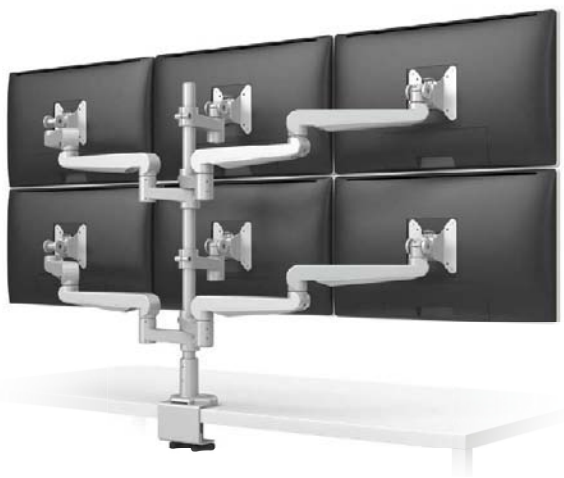

EVOLVE6-FF

FIXED + FIXED
MANUAL HEIGHT ADJUSTMENT

- Outside Monitor Extension: 26.75"
- Center Monitor Extension: 6"
- Monitor Tilt: +25°/-90°
- Monitor Rotation: +90°/-90°
- 180° Lock-Out Feature
- Quick Release
- 28" Pole
- Weight Capacity (per arm):
 - Minimum: N/A
 - Maximum: 20 lbs
- Max Monitor Width: 21.5" (bezel measured left to right)

PART #	LIST PRICE
● EVOLVE6-FF-SLV	\$1,302



EVOLVE6-FMS

FIXED + MOTION + SLIDER
DYNAMIC HEIGHT ADJUSTMENT

- Outside Monitor Extension: 28.75"
- Center Monitor Extension: 6"
- Monitor Tilt: +60°/-80°
- Monitor Rotation: +90°/-90°
- 180° Lock-Out Feature
- Quick Release
- 28" Pole
- Weight Capacity (per arm):
 - Minimum: 4.4 lbs
 - Maximum: 15.4 lbs
- Max Monitor Width: 32" (bezel measured left to right)

PART #	LIST PRICE
● EVOLVE6-FMS-SLV	\$1,846



THE ALL-IN-ONE SOLUTION

The EDGE-MAX-DUAL is ideal for all-in-one computers or Apple® Thunderbolt® displays.

The EDGE-MAX series is designed to support heavier monitors including most all-in-one computers and Apple® Thunderbolt® displays.



EDGE-MAX SINGLE MONITOR ARM

- DYNAMIC HEIGHT ADJUSTMENT
- Height Adjustment Range:
 - LOW: 9" | HIGH: 23"
 - TOTAL RANGE: 14"
 - Monitor Extension: 22.4"
 - Monitor Tilt: +35°/-85°
 - Monitor Rotation: +90°/-90°
 - 360° rotation at three points
 - Weight Capacity (per arm):
 - Minimum: 17.6 lbs
 - Maximum: 44 lbs

PART #	LIST PRICE
● EDGE-MAX-SLV	\$516



HEAVY LIFTER
Each arm supports over 40 lbs!

EDGE-MAX-DUAL FOR HEAVY MONITORS



DYNAMIC HEIGHT ADJUSTMENT

- Height Adjustment Range:
 - LOW: 9" | HIGH: 23"
 - TOTAL RANGE: 14"
- Monitor Extension: 22.4"
- Monitor Tilt: +35°/-85°
- Monitor Rotation: +90°/-90°
- 360° rotation at three points
- Quick Release
- Weight Capacity (per arm):
 - Minimum: 17.6 lbs
 - Maximum: 42 lbs
- Max Monitor Width: 32" (bezel measured left to right)

PART #	LIST PRICE
● EDGE-MAX-DUAL-SLV	\$1,215

MINIMUM ORDER QUANTITY REQUIRED

EDGE2-MAX COMBINED DUAL MONITOR ARM

DYNAMIC HEIGHT ADJUSTMENT

- Height Adjustment Range:
 - LOW: 9" | HIGH: 23"
 - TOTAL RANGE: 14"
- Monitor Extension: 26.7"
- Monitor Tilt: +55°/-55°
- Monitor Rotation: +90°/-90°
- 360° rotation at two points
- Weight Capacity (total):
 - Minimum: 12 lbs
 - Maximum: 38.5 lbs
- Total width of crossbar: 30.25"
- Max Monitor Width: 24" (bezel measured left to right)

PART #	LIST PRICE
● EDGE2-MAX-SLV	\$769

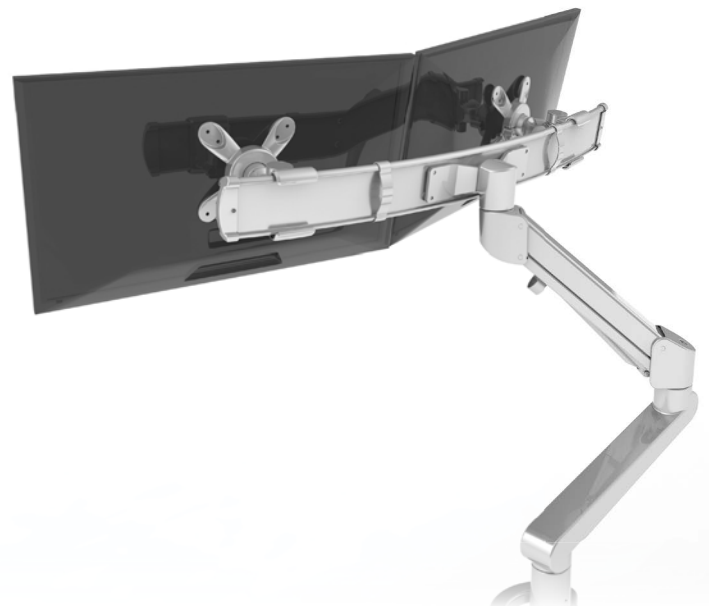



SLIDER MOUNT

VESA SLIDER

- Up to 9" of adjustment from left to right
- Retrofittable with the EDGE and EVOLVE series
- Not compatible with the EDGE-MAX series
- Adds an additional 2.2 lbs

PART #	LIST PRICE
EDV-SLD-SLV	\$135



EDGE-SLAT SLAT WALL MOUNT

- EDGE arm with Slat Mount
- Monitor Extension: 15"
- Fits slot/rail in widths of .75" - 2.75"
- Monitor Tilt: +25°/-90°
- Monitor Rotation: +90°/-90°
- Weight Capacity:
 - Minimum: 6.5 lbs
 - Maximum: 17.6 lbs

PART #	LIST PRICE
EDGE-SLAT-SLV	\$341

VESA-HVY

WEIGHTED MOUNT

For use when monitor weight does not meet minimum weight requirement for monitor arm

- Adds an additional 2.39 lbs

PART #	LIST PRICE
VESA-HVY-SLV	\$45



ENCLOZE

NON-VESA MONITOR CONVERSION BRACKET

- Compatible with EDGE or EVOLVE Series
- Weight Capacity:
 - Minimum: N/A
 - Maximum: 14 lbs
- Width Limit: 17" - 23"
- Height Limit: 11" - 14.5"
- Depth Limit: 1.6" (outside casing)



PART #	LIST PRICE
ENCLOZE-BLK	\$204

MONITOR ARM SOLD SEPARATELY

EDGE-WALL WALL MOUNT

- EDGE arm with Wall Mount
- Monitor Extension: 24"
- Monitor Tilt: +25°/-90°
- Monitor Rotation: +90°/-90°
- Weight Capacity:
 - Minimum: 6.5 lbs
 - Maximum: 17.6 lbs



PART #	LIST PRICE
EDGE-WALL-SLV	\$341

VESA 100X200

CONVERSION MOUNT

Converts a 75mm or 100mm VESA mount to attach to a 100mm x 200mm VESA display



PART #	LIST PRICE
VESA 100X200-SLV	\$28

BENCHING SOLUTIONS

MONITOR ARM ADAPTERS

Benching mounts are not compatible with all benching systems. Call Customer Service for compatibility details.

The E-SMT will accommodate tops from 1" to 1-3/16" in thickness.

MONITOR ARM SOLD SEPARATELY

PART #	SYSTEM	LIST PRICE
E-AMT-SLV	KNOLL® ANTENNA	\$106
E-CMT-SLV	STEELCASE® C:SCAPE (SHOWN)	\$139
E-FOMT-SLV	STEELCASE® FRAMEONE	\$125
E-SMT-SLV	ALLSTEEL® STRIDE	\$91



With the ESI collection of height adjustable tables, sitting is no longer the only option for workstations, conference rooms, breakout rooms, and collaborative spaces.

EVOLVE3-FMS
Page 12

LUSTRE
Page 39

CPUMINI
Page 36

CONCEAL
See below



CONCEAL
CABLE MANAGEMENT

The CONCEAL expands and retracts to keep cables organized under a height adjustable table base.

- Total Height: 53.5"
- Total # of links: 23
- Links are detachable
- Weighted bottom
- Attaches to bottom of work surface

PART #	LIST PRICE
● CONCEAL-GRY	\$61
● CONCEAL-BLK	\$61

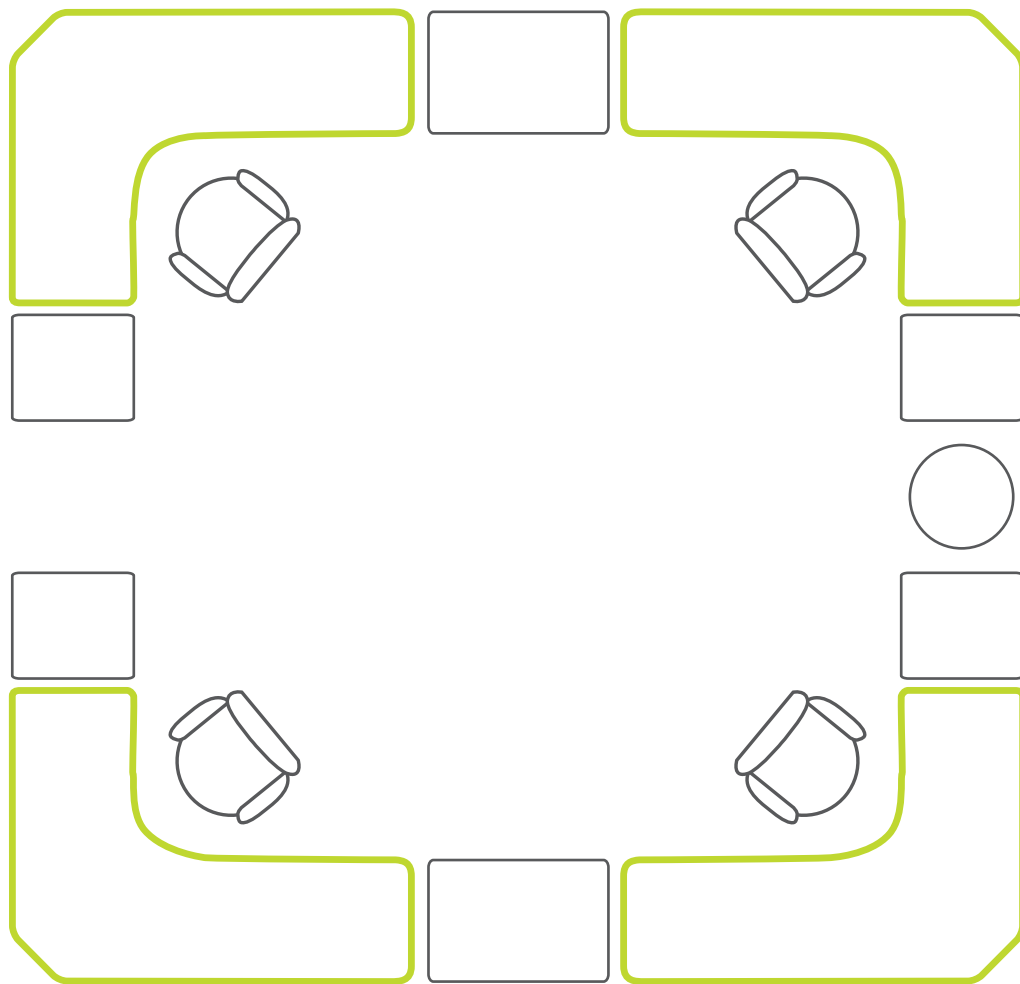

HYBRID WORKSTATION

ESI height adjustable table bases can be used in virtually any environment. This “hybrid” workstation provides a balance of privacy and collaboration. By positioning the workstations facing outward, employees have their own private space. At the same time, fellow employees are just a few steps away, promoting quick collaboration.

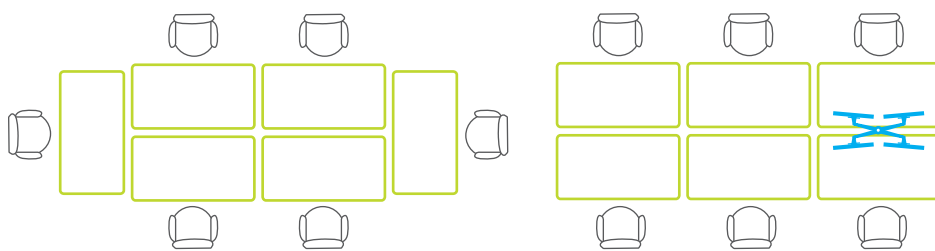

OPEN FLOOR PLAN?

One **EVOLVE4-FMS** provides dual monitor arms for two facing workstations.

A Height Adjustable Workstation combined with a Keyboard Solution, CPU Holder, LED Task Light, and Monitor Arm creates an ergonomic and healthy workstation.



EDGE-MAX-DUAL
Page 14

PIXIE-LEDX
Page 38

SOLUTION ALL-FIT
See below

CPU01
Page 36



SOLUTION ALL-FIT

Ideal for shallow work surfaces 13" deep or larger, characteristic of benching systems and height adjustable tables.

PL003-27N NOTCHED KEYBOARD PLATFORM
• 27" platform with notched cutout

PART #

SOLUTION ALL-FIT

LIST PRICE

\$406

AA100 LIFT & LOCK ARTICULATING ARM

- Lift and Lock height adjustment
- +10°/-20° tilt adjustment and 360° rotation
- 12.75" Glide Track
- Height Adjustment Range: 6"
- 2-3/8" above track | 3-5/8" below track
- Fully retracts on a 13" work surface

DIGITAL KEYPAD
TRIUMPH UPGRADE



- Digital programmable switch with 3 memory settings
- Low Standby Power Consumption
- Included with Silver and Black TRIUMPH bases

PART #

DGTLKPD-VE3

LIST PRICE

\$125

TRIUMPH



ELECTRIC TABLE BASE

TECHNICAL SPECIFICATIONS

- Silver and Black table base finishes include programmable digital keypad with 3 memory settings
- Height Adjustment Range: 19.5"
 - LOW: 26" | HIGH 45.5"
- Adjustment Speed: 1.4"/second
- Lifting Capacity: 180 lbs
- Adjustable Cross Channels
- Soft Start feature allows the user to ease-in to a height adjustment
- Anti-Collision Safety Feature

TABLE BASE COLOR OPTIONS

- SILVER (-SLV)
- BLACK (-BLK)
- WHITE (-WHT)

Example: 2T-C28-24-**BLK** represents your order for a **BLACK TRIUMPH** table base



CASTERS

Set of 4 casters for TRIUMPH 2 leg

- Increases height by 2"

PART #	LIST PRICE
CASTER-SP2 4 CASTERS	\$64

AVAILABLE 2 LEG WORK SURFACES

*CALL CUSTOMER SERVICE FOR 120° WORK SURFACE OPTIONS.



RECTANGLE

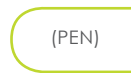

PENINSULA



SMALL EQUAL CORNER



120 DEGREE*

2T-C28-24 & 2T-C28-30
WIDTH ADJUSTS FROM

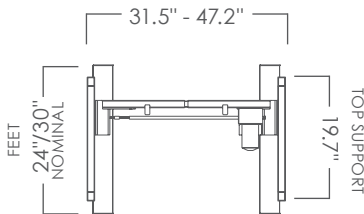

2T-C40-24 & 2T-C40-30
WIDTH ADJUSTS FROM

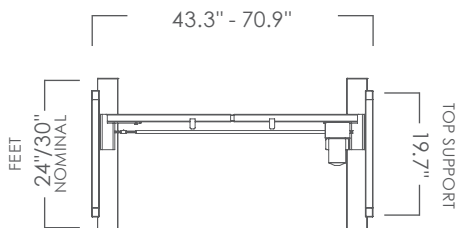

TRIUMPH 2 LEG ORDERING OPTIONS

	DIMENSIONS			BASE PART # SPECIFY COLOR PREFERENCE	BASE LIST	SURFACE PART # SEE ORDERING DETAILS PG 29	SURFACE LIST
	WL	WR	D				
RECTANGLE	36	24	24	2T-C28-24-___	\$1,244	2R3624__	\$356
	42	24	24	2T-C28-24-___	\$1,244	2R4224__	\$388
	48	24	24	2T-C28-24-___	\$1,244	2R4824__	\$388
	60	24	24	2T-C40-24-___	\$1,264	2R6024__	\$489
	72	24	24	2T-C40-24-___	\$1,264	2R7224__	\$721
	36	30	24	2T-C28-30-___	\$1,270	2R3630__	\$417
	42	30	24	2T-C28-30-___	\$1,270	2R4230__	\$418
	48	30	24	2T-C28-30-___	\$1,270	2R4830__	\$418
PEN	60	30	30	2T-C40-30-___	\$1,296	2R6030__	\$546
	72	30	30	2T-C40-30-___	\$1,296	2R7230__	\$752
	60	30	30	2T-C40-30-___	\$1,296	P6030__	\$1,100
SEC	72	30	30	2T-C40-30-___	\$1,296	P7230__	\$1,121
	42	42	24	2T-C28-24-___	\$1,244	2EC424224__	\$1,100
	48	48	24	2T-C28-24-___	\$1,244	2EC484824__	\$1,136

WORK SURFACES ARE NOT SOLD SEPARATELY. SEE PAGE 29 FOR DETAILS.

VICTORY



ELECTRIC TABLE BASE

TECHNICAL SPECIFICATIONS

- Height Adjustment Range: 25.3"
 - LOW: 24.4" | HIGH: 49.7"
- Adjustment Speed: 1.4"/second
- Lifting Capacity:
 - 220 lbs (2-leg) / 330 lbs (3-leg)
- Adjustable Cross Channels
- Soft Start feature allows the user to ease-in to a height adjustment
- Anti-Collision Safety Feature

TABLE BASE COLOR OPTIONS

- SILVER (-SLV)
- BLACK (-BLK)
- WHITE (-WHT)

Example: 2VT-C36-24-**BLK** represents your order for a **BLACK** VICTORY table base



CASTERS

Set of 4 casters for VICTORY 2 leg

- Increases height by 2"

PART # _____ LIST PRICE
CASTER-SP2 4 CASTERS **\$64**

AVAILABLE 2 LEG WORK SURFACES

*CALL CUSTOMER SERVICE FOR 120° WORK SURFACE OPTIONS.



RECTANGLE



PENINSULA



SMALL EQUAL CORNER



120 DEGREE*

2VT-C36-24 & 2VT-C36-30
WIDTH ADJUSTS FROM

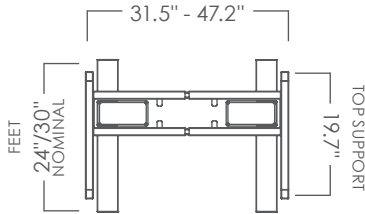

2VT-C48-24 & 2VT-C48-30
WIDTH ADJUSTS FROM

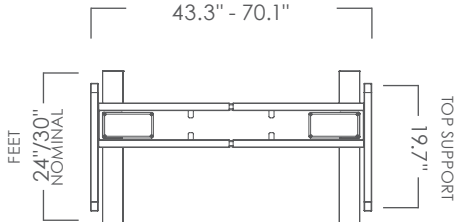

VICTORY 2 LEG ORDERING OPTIONS

	DIMENSIONS			BASE PART # SPECIFY COLOR PREFERENCE	BASE LIST	SURFACE PART # SEE ORDERING DETAILS PG 29	SURFACE LIST
	WL	WR	D				
RECTANGLE	36	24		2VT-C36-24-___	\$1,735	2R3624__	\$356
	42	24		2VT-C36-24-___	\$1,735	2R4224__	\$388
	48	24		2VT-C48-24-___	\$1,757	2R4824__	\$388
	60	24		2VT-C48-24-___	\$1,757	2R6024__	\$489
	72	24		2VT-C48-24-___	\$1,757	2R7224__	\$721
	36	30		2VT-C36-30-___	\$1,817	2R3630__	\$417
	42	30		2VT-C36-30-___	\$1,817	2R4230__	\$418
PEN	48	30		2VT-C48-30-___	\$1,839	2R4830__	\$418
	60	30		2VT-C48-30-___	\$1,839	2R6030__	\$546
	72	30		2VT-C48-30-___	\$1,839	2R7230__	\$752
SEC	60	30		2VT-C48-30-___	\$1,839	P6030__	\$1,100
	72	30		2VT-C48-30-___	\$1,839	P7230__	\$1,121
SEC	42	42	24	2VT-C36-24-___	\$1,735	2EC424224__	\$1,100
	48	48	24	2VT-C36-24-___	\$1,735	2EC484824__	\$1,136

WORK SURFACES ARE NOT SOLD SEPARATELY. SEE PAGE 29 FOR DETAILS.



DIGITAL KEYPAD
VICTORY UPGRADE



- Digital programmable switch with 3 memory settings
- Low Standby Power Consumption

PART # _____ LIST PRICE
DGTLKPD-VE3 **\$125**

AVAILABLE 3 LEG WORK SURFACES

*CALL CUSTOMER SERVICE FOR 120° WORK SURFACE OPTIONS.



LARGE EQUAL CORNER



120 DEGREE*



OFFSET CORNER RIGHT



OFFSET CORNER LEFT



PENINSULA RIGHT (PEN RIGHT)



PENINSULA LEFT (PEN LEFT)

VICTORY 3 LEG ORDERING OPTIONS

	DIMENSIONS			BASE PART # SPECIFY COLOR PREFERENCE	BASE LIST	SURFACE PART # SEE ORDERING DETAILS PG 29	SURFACE LIST
	WL	WR	D				
LARGE EQUAL CORNER	60	60	24	3VT-C4848-24_	\$2,246	3EC606024_	\$1,038
	72	72	24	3VT-C4848-24_	\$2,246	3EC727224_	\$1,860
	60	60	30	3VT-C4848-30_	\$2,271	3EC606030_	\$1,038
	72	72	30	3VT-C4848-30_	\$2,271	3EC727230_	\$1,860
OFFSET CORNER LEFT	60	48	24	3VT-C4836-24_	\$2,154	3OCL604824_	\$1,100
	72	48	24	3VT-C4836-24_	\$2,154	3OCL724824_	\$1,105
	72	60	24	3VT-C4848-24_	\$2,246	3OCL726024_	\$1,110
	60	48	30	3VT-C4836-30_	\$2,198	3OCL604830_	\$1,100
OFFSET CORNER RIGHT	72	48	30	3VT-C4836-30_	\$2,198	3OCL724830_	\$1,105
	72	60	30	3VT-C4848-30_	\$2,271	3OCL726030_	\$1,110
	48	60	24	3VT-C4836-24_	\$2,154	3OCR486024_	\$1,100
	48	72	24	3VT-C4836-24_	\$2,154	3OCR487224_	\$1,105
PEN LEFT	60	72	24	3VT-C4848-24_	\$2,246	3OCR607224_	\$1,110
	48	60	30	3VT-C4836-30_	\$2,198	3OCR486030_	\$1,100
	48	72	30	3VT-C4836-30_	\$2,198	3OCR487230_	\$1,105
	60	72	30	3VT-C4848-30_	\$2,271	3OCR607230_	\$1,110
PEN RIGHT	72	48	30	3VT-C4836-30_	\$2,198	3PL724830_	\$1,033
	72	60	30	3VT-C4848-30_	\$2,271	3PL726030_	\$1,085
PEN LEFT	48	72	30	3VT-C4836-30_	\$2,198	3PR487230_	\$1,033
	60	72	30	3VT-C4848-30_	\$2,271	3PR607230_	\$1,085

WORK SURFACES ARE NOT SOLD SEPARATELY. SEE PAGE 29 FOR DETAILS.

3VT-C3648-24 & 3VT-C3648-30
WIDTH ADJUSTS FROM

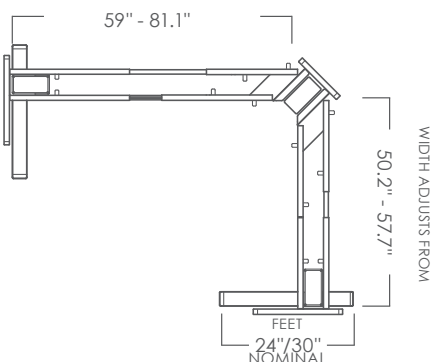

3VT-C4848-24
WIDTH ADJUSTS FROM

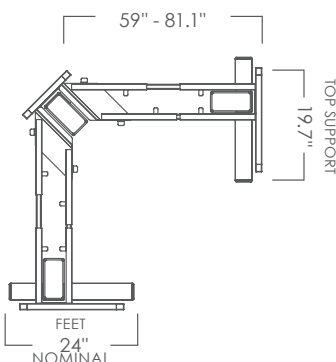

3VT-C4848-30
WIDTH ADJUSTS FROM

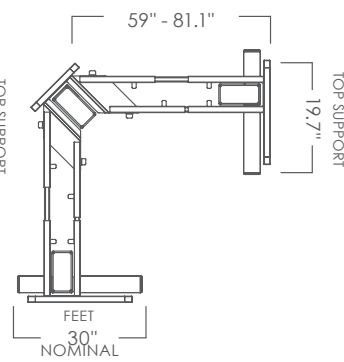

For more information and options, please visit our website at esiergo.com

48 HOUR SHIPPING



PREMIUM ELECTRIC TABLE BASE



TECHNICAL SPECIFICATIONS

- Height Adjustment Range: 26"
 - LOW: 22" | HIGH: 48"
- Adjustment Speed: 1.5"/second
- Lifting Capacity:
 - 220 lbs (2-leg) / 300 lbs (3-leg)
- Soft Start feature allows the user to ease-in to a height adjustment
- Anti-Collision Safety Feature

TABLE BASE COLOR OPTIONS

SILVER

CASTERS

Set of 4 casters for PREMIUM 2 leg

- Increases height by 2"

PART # CASTER-OV2 4 CASTERS LIST PRICE **\$64**

DIGITAL KEYPAD

PREMIUM UPGRADE



- Digital programmable switch with 3 memory settings
- Low Standby Power Consumption

PART # DGTLKPD-PE LIST PRICE **\$141**

AVAILABLE 2 LEG WORK SURFACES



RECTANGLE

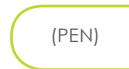

PENINSULA

PREMIUM 2 LEG ORDERING OPTIONS

	DIMENSIONS		BASE PART #	BASE LIST	SURFACE PART # <small>SEE ORDERING DETAILS PG 29</small>	SURFACE LIST
	W	D				
RECTANGLE	36	24	2E-C36-24-SLV	\$2,451	2R3624__	\$356
	42	24	2E-C36-24-SLV	\$2,451	2R4224__	\$388
	48	24	2E-C48-24-SLV	\$2,451	2R4824__	\$388
	60	24	2E-C60-24-SLV	\$2,461	2R6024__	\$489
	72	24	2E-C72-24-SLV	\$2,482	2R7224__	\$721
	36	30	2E-C36-30-SLV	\$2,453	2R3630__	\$417
	42	30	2E-C36-30-SLV	\$2,453	2R4230__	\$418
	48	30	2E-C48-30-SLV	\$2,453	2R4830__	\$418
	60	30	2E-C60-30-SLV	\$2,463	2R6030__	\$546
PEN	72	30	2E-C72-30-SLV	\$2,484	2R7230__	\$752
	60	30	2E-C60-30-SLV	\$2,463	P6030__	\$1,100
	70	30	2E-C72-30-SLV	\$2,484	P7230__	\$1,121

WORK SURFACES ARE NOT SOLD SEPARATELY. SEE PAGE 29 FOR DETAILS.



AVAILABLE 3 LEG WORK SURFACES

*CALL CUSTOMER SERVICE FOR 120° WORK SURFACE OPTIONS.



LARGE EQUAL CORNER



120 DEGREE*

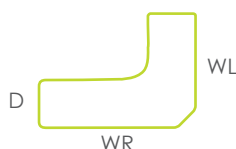

OFFSET CORNER RIGHT



OFFSET CORNER LEFT



PENINSULA RIGHT (PEN RIGHT)



PENINSULA LEFT (PEN LEFT)

CASTERS

Set of 5 casters for PREMIUM 3 leg

- Increases height by 2"

PART # **CASTER-OV3** 5 CASTERS LIST PRICE **\$104**

PREMIUM 3 LEG ORDERING OPTIONS

	DIMENSIONS			BASE PART #	BASE LIST	SURFACE PART # <small>SEE ORDERING DETAILS PG 29</small>	SURFACE LIST
	WL	WR	D				
LARGE EQUAL CORNER	60	60	24	3E90-C6060-24-SLV	\$3,744	3EC606024__	\$1,038
	72	72	24	3E90-C7272-24-SLV	\$3,786	3EC727224__	\$1,860
	60	60	30	3E90-C6060-30-SLV	\$3,746	3EC606030__	\$1,038
	72	72	30	3E90-C7272-30-SLV	\$3,788	3EC727230__	\$1,860
OFFSET CORNER LEFT	60	48	24	3E90-C4860-24-SLV	\$3,734	3OCL604824__	\$1,100
	72	48	24	3E90-C4872-24-SLV	\$3,755	3OCL724824__	\$1,105
	72	60	24	3E90-C6072-24-SLV	\$3,765	3OCL726024__	\$1,110
	60	48	30	3E90-C4860-30-SLV	\$3,736	3OCL604830__	\$1,100
OFFSET CORNER RIGHT	72	48	30	3E90-C4872-30-SLV	\$3,757	3OCL724830__	\$1,105
	72	60	30	3E90-C6072-30-SLV	\$3,767	3OCL726030__	\$1,110
	48	60	24	3E90-C4860-24-SLV	\$3,734	3OCR486024__	\$1,100
	48	72	24	3E90-C4872-24-SLV	\$3,755	3OCR487224__	\$1,105
PENINSULA LEFT	60	72	24	3E90-C6072-24-SLV	\$3,765	3OCR607224__	\$1,110
	48	60	30	3E90-C4860-30-SLV	\$3,736	3OCR486030__	\$1,100
	48	72	30	3E90-C4872-30-SLV	\$3,757	3OCR487230__	\$1,105
	60	72	30	3E90-C6072-30-SLV	\$3,767	3OCR607230__	\$1,110
PEN LEFT	72	48	30	3E90-C4872-30-SLV	\$3,757	3PL724830__	\$1,033
	72	60	30	3E90-C6072-30-SLV	\$3,767	3PL726030__	\$1,085
PEN RIGHT	48	72	30	3E90-C4872-30-SLV	\$3,757	3PR487230__	\$1,033
	60	72	30	3E90-C6072-30-SLV	\$3,767	3PR607230__	\$1,085

WORK SURFACES ARE NOT SOLD SEPARATELY. SEE PAGE 29 FOR DETAILS.

work·space·o·lo·gy[®]

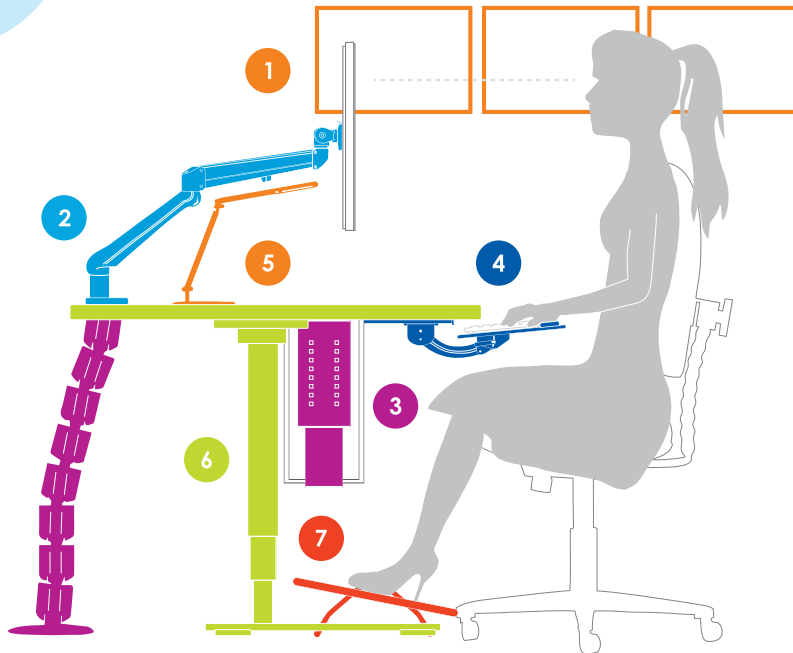

RESEARCHING CRITICAL ELEMENTS OF A HEALTHY & PRODUCTIVE WORK SPACE

- 1** Access to natural light improves productivity and well-being.
- 2** **Adjustable monitor arms** help eliminate the tendency to sit in awkward positions by maintaining the proper viewing distance, height and angle of the monitor. Monitor arms keep the neck, shoulders and back in the proper posture to reduce muscle fatigue. They also free up the workspace to reduce clutter and increase efficiency. Using dual monitors can increase productivity over a single monitor.
- 3** **CPU holders** raise the CPU off the floor, making them easier for the user to reach and reducing the tendency to stretch into an awkward position. CPU holders also help free up leg room under the user's workstation.
- 4** **Adjustable keyboard platforms** help maintain a neutral wrist position and eliminate strain, improper posture, and discomfort. Proper keyboard positioning can help eliminate musculoskeletal disorders.
- 5** **Energy efficient task lighting** can reduce energy consumption and costs. Adjustable task lights give the user maximum control of their own workspace lighting for optimal comfort, and help reduce eyestrain and fatigue.
- 6** **Height adjustable workstations** give users the flexibility to change positions frequently and easily throughout the day, which improves health and productivity.
- 7** **Footrests** can help decrease circulation problems that can occur from long periods of sitting or inactivity. By supporting the legs, footrests can relieve pressure on the lower back.



1

2

5

4

6

3

7

Q CRANK

HAND CRANK TABLE BASE



TECHNICAL SPECIFICATIONS

- Height Adjustment Range: 17.7"
 - LOW: 24.8 | HIGH: 42.5
- Adjustment Speed: 1" per 2 cranks
- Lifting Capacity: 220 lbs
- Adjustable Cross Channels

TABLE BASE COLOR OPTIONS

● SILVER

CASTERS

Set of 4 casters for Q CRANK

- Increases height by 2"

PART #	LIST PRICE
CASTER-SP2	\$64



AVAILABLE WORK SURFACES

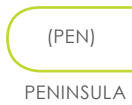

Q CRANK-24S & Q CRANK-30S WIDTH ADJUSTS FROM

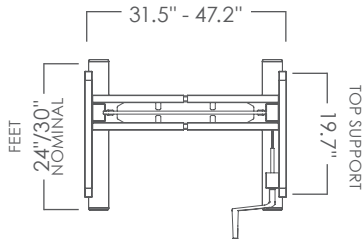

Q CRANK-24L & Q CRANK-30L WIDTH ADJUSTS FROM

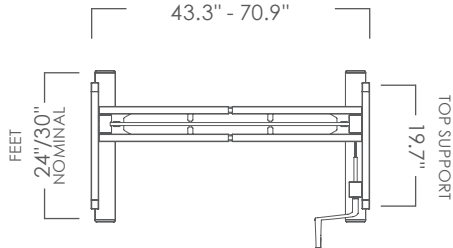

Q CRANK 2 LEG ORDERING GUIDE

	DIMENSIONS		BASE PART #	BASE LIST	SURFACE PART # <small>SEE ORDERING DETAILS PG 29</small>	SURFACE LIST
	W	D				
RECTANGLE	36	24	Q CRANK-24S-SLV	\$1,085	2R3624__	\$356
	42	24	Q CRANK-24S-SLV	\$1,085	2R4224__	\$388
	48	24	Q CRANK-24S-SLV	\$1,085	2R4824__	\$388
	60	24	Q CRANK-24L-SLV	\$1,118	2R6024__	\$489
	72	24	Q CRANK-24L-SLV	\$1,118	2R7224__	\$721
	36	30	Q CRANK-30S-SLV	\$1,100	2R3630__	\$417
PEN	42	30	Q CRANK-30S-SLV	\$1,100	2R4230__	\$418
	48	30	Q CRANK-30S-SLV	\$1,100	2R4830__	\$418
	60	30	Q CRANK-30L-SLV	\$1,133	2R6030__	\$546
	72	30	Q CRANK-30L-SLV	\$1,133	2R7230__	\$752
	60	30	Q CRANK-30L-SLV	\$1,133	P6030__	\$1,100
	72	30	Q CRANK-30L-SLV	\$1,133	P7230__	\$1,121

WORK SURFACES ARE NOT SOLD SEPARATELY. SEE PAGE 29 FOR DETAILS.

ESPREE

PNEUMATIC TABLE BASE

TECHNICAL SPECIFICATIONS

- Height Adjustment Range: 20"
 - LOW: 26" | HIGH: 46"
- Adjustable feet (22" or 28" long)
- Lifting Capacity (including work surface):
 - 2ESP-C48-ADJ: 38 lbs - 83 lbs
 - 2ESP-C60-ADJ: 49 lbs - 94 lbs
- Table bases accommodate work surfaces measuring 48" and 60" in width
- Counterbalanced columns provide smooth, synchronized height adjustment

TABLE BASE COLOR OPTIONS

● SILVER

AVAILABLE WORK SURFACES



RECTANGLE



PENINSULA

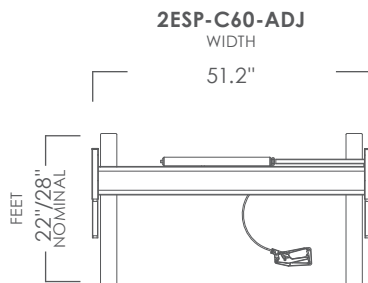
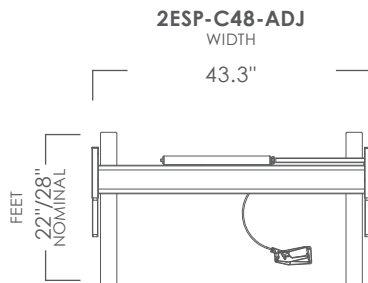

ESPREE 2 LEG ORDERING GUIDE

	DIMENSIONS		BASE PART #	BASE LIST	SURFACE PART # <small>SEE ORDERING DETAILS PG 29</small>	SURFACE LIST
	W	D				
RECTANGLE	48	24	2ESP-C48-ADJ-SLV	\$1,665	2R4824_ _	\$388
	48	30	2ESP-C48-ADJ-SLV	\$1,665	2R4830_ _	\$418
	60	24	2ESP-C60-ADJ-SLV	\$1,699	2R6024_ _	\$489
	60	30	2ESP-C60-ADJ-SLV	\$1,699	2R6030_ _	\$546
PEN	60	30	2ESP-C60-ADJ-SLV	\$1,699	P6030_ _	\$1,100

WORK SURFACES ARE NOT SOLD SEPARATELY. SEE PAGE 29 FOR DETAILS.

CORE

SINGLE COLUMN ELECTRIC TABLE BASE



TECHNICAL SPECIFICATIONS

- Height Adjustment Range: 18.9"
 - LOW: 25.8" | HIGH: 44.7"
- Adjustment Speed: 1.4"/sec
- Lifting Capacity: 132 lbs
- Soft Start feature allows the user to ease-in to a height adjustment
- Anti-Collision Safety Feature

TABLE BASE COLOR OPTIONS

SILVER

AVAILABLE WORK SURFACES



DIGITAL KEYPAD CORE UPGRADE



- Digital programmable switch with 3 memory settings
- Low Standby Power Consumption

PART # **DGTLKPD-VE3** LIST PRICE **\$125**

CORE SINGLE COLUMN ORDERING GUIDE

	DIMENSIONS		BASE PART #	BASE LIST	SURFACE PART # <small>SEE ORDERING DETAILS PG 29</small>	SURFACE LIST
	W	D				
RECTANGLE	36	24	CORE-SLV	\$1,292	2R3624_ _	\$356
	42	24	CORE-SLV	\$1,292	2R4224_ _	\$388
	36	30	CORE-SLV	\$1,292	2R3630_ _	\$417
	42	30	CORE-SLV	\$1,292	2R4230_ _	\$418
	36	24	CORE-WM-SLV	\$1,291	2R3624_ _	\$356
	42	24	CORE-WM-SLV	\$1,291	2R4224_ _	\$388
	36	30	CORE-WM-SLV	\$1,291	2R3630_ _	\$417
	42	30	CORE-WM-SLV	\$1,291	2R4230_ _	\$418
SEC	48	24	CORE-SLV	\$1,292	2EC424224_ _	\$1,100
	42	24	CORE-SLV	\$1,292	2EC484824_ _	\$1,136

WORK SURFACES ARE NOT SOLD SEPARATELY. SEE PAGE 29 FOR DETAILS.



WALL-MOUNTED
Save on space by mounting the CORE directly to a wall

CORE-WM WALL-MOUNTED ELECTRIC TABLE BASE



TABLE BASE COLOR OPTIONS

SILVER

AVAILABLE WORK SURFACES



STANDARD WORK SURFACES



WORK SURFACES ARE NOT SOLD SEPARATELY. TABLE BASE MUST BE PURCHASED TO ORDER A WORK SURFACE. Typical lead time is 10-14 business days for production of work surfaces. Please indicate laminate choice by adding the 2-letter code at the end of the Work Surface Part Number.

2R4830KM = 48" x 30" Rectangle Work Surface in *Kensington Maple*

LAMINATE GUIDE

Work surfaces are available in 38 standard Wilsonart® laminate colors. Standard laminates ship with matching 3mm edge banding. Additional laminate colors may be available. Call Customer Service for more information.

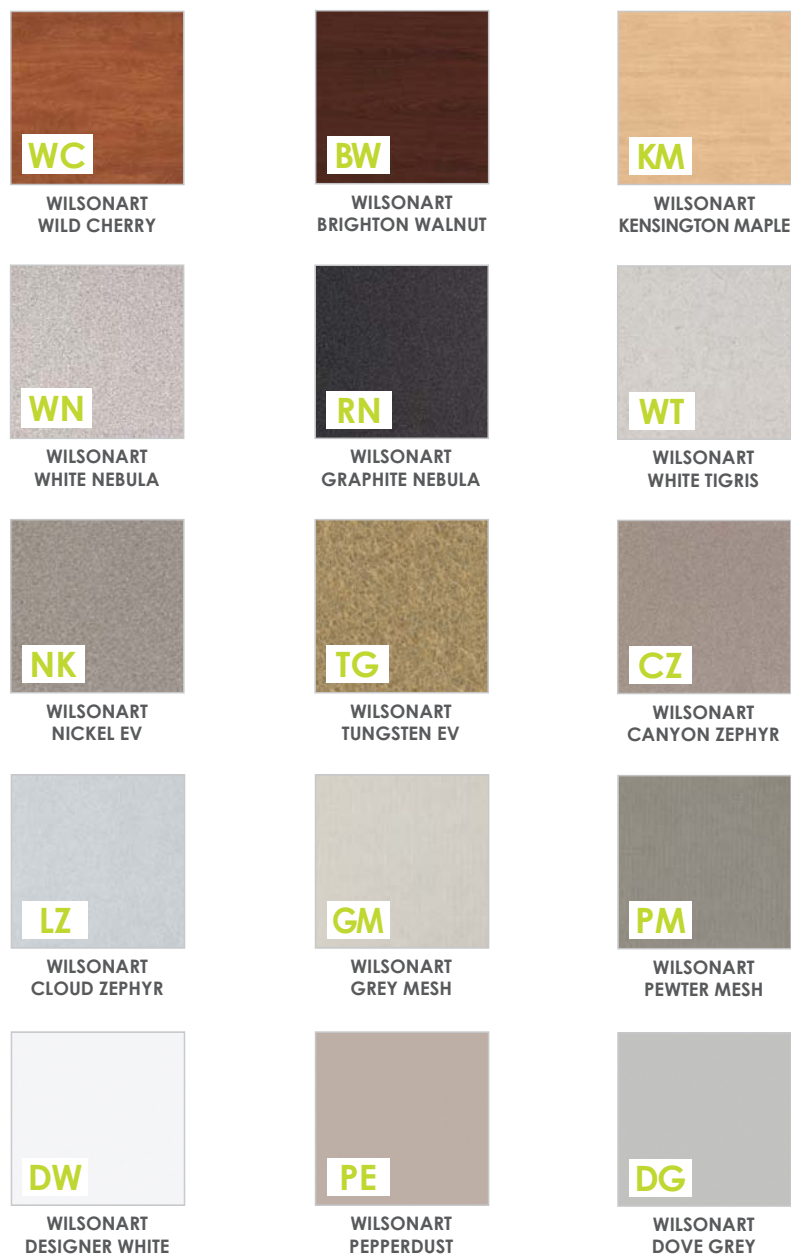

STANDARD LAMINATE	
WOOD GRAINS	BE BEIGEWOOD
	BW BRIGHTON WALNUT
	CO CASTLE OAK
	FM FUSION MAPLE
	KM KENSINGTON MAPLE
	MM MONTICELLO MAPLE
	SC SHAKER CHERRY
	SO SOLAR OAK
	WC WILD CHERRY
PATTERNS	CZ CANYON ZEPHYR
	CN CLOUD NEBULA
	LZ CLOUD ZEPHYR
	DZ DESERT ZEPHYR
	RN GRAPHITE NEBULA
	GM GREY MESH
	GN GREY NEBULA
	NZ LODEN ZEPHYR
	MZ MISTED ZEPHYR
	OZ MORRO ZEPHYR
	NK NICKEL EV
	PM PEWTER MESH
	SZ SHADOW ZEPHYR
	SM SHEER MESH
	SI SILICON EV
	PZ SPICED ZEPHYR
	TT TITANIUM EV
	TG TUNGSTEN EV
	TZ TWILIGHT ZEPHYR
WN WHITE NEBULA	
WT WHITE TIGRIS	
SOLIDS	AW ANTIQUE WHITE
	BK BLACK
	DW DESIGNER WHITE
	DG DOVE GREY
	FW FROSTY WHITE
	NS NORTH SEA
	PE PEPPERDUST
	WS WHITE SAND

* NOTE: DUE TO PRINTING LIMITATIONS, COLORS ARE NOT GUARANTEED TO BE ACCURATELY REPRODUCED.

ERGORISE SERIES

SIT-TO-STAND WORKSTATIONS

The ErgoRise series introduces budget friendly sit-to-stand solutions.



EDGE
An EDGE
monitor arm
can easily be
added on to
the LIFT



ERGORISE LIFT
SIT-TO-STAND WORKSTATION

- Clamps to the back of the work surface
- Can mount to work surfaces 30" deep or less
- 4" of clearance is needed underneath work surface for clamp
- Pneumatic height adjustment
- Weight Capacity: 20 lbs
- Height Adjustment Range: 16"
- Top Platform: 27" X 15.75"
- Top platform includes grommet hole for cable management
- Keyboard Platform: 27" X 10.5"
- Keyboard platform includes palm rest
- Palm rest can be positioned on left or right side of keyboard platform

PART #

LIST PRICE

LIFT-SLV

\$515

MONITOR ARM SOLD SEPARATELY



ERGORISE LIFT-WB
SIT-TO-STAND WORKSTATION

- Compatible with work surfaces 23" deep or more
- Wooden base allows for flexible positioning and placement on a work surface
- Pneumatic height adjustment
- Weight Capacity: 20 lbs
- Height Adjustment Range: 16"
- Top Platform: 27" X 15.75"
- Top platform includes grommet hole for cable management
- Keyboard Platform: 27" X 10.5"
- Keyboard platform includes palm rest
- Palm rest can be positioned on left or right side of keyboard platform

PART #

LIST PRICE

LIFT-WB-SLV

\$623





EASY ACCESS
Transitioning from sit to stand is simple, convenient, and always within reach.





ERGORISE CLIMB2
DUAL MONITOR ARM
SIT-TO-STAND WORKSTATION

- Height adjustable pneumatic arm
- Clamps to the back of the work surface
 - Designed for work surfaces 30" deep or less
 - 6" of clearance is needed underneath the work surface for the desk clamp
 - Pneumatic Height Adjustment
 - Weight Capacity: 16 lbs
 - Height Adjustment Range: 17"
 - Keyboard Platform: 26.5" x 10.5"
 - Keyboard Platform includes palm rest
 - Palm rest can be positioned on the left or right side of the keyboard platform
 - Monitors can be rotated for viewing in landscape or portrait orientations
 - Monitors are fixed at an 8° angle toward each other
 - Monitors can move horizontally 7.5"
 - Monitors can be adjusted 12" vertically along the mount
 - Arm can be adjusted 19.5" up and down the pole

GROMMET MOUNT

Grommet Mount for CLIMB1 or CLIMB2.

PART #	LIST PRICE
CLIMB-GM-SLV	\$35

PRICE INCLUDES GROMMET MOUNT ONLY. CLIMB1 OR CLIMB2 MUST BE PURCHASED IN ADDITION TO THE GROMMET MOUNT.

ERGORISE CLIMB1
SINGLE MONITOR ARM
SIT-TO-STAND WORKSTATION

- Height adjustable pneumatic arm
- Clamps to the back of the work surface
 - Designed for work surfaces 30" deep or less
 - 6" of clearance is needed underneath the work surface for the desk clamp
 - Pneumatic Height Adjustment
 - Weight Capacity: 20 lbs
 - Height Adjustment Range: 17"
 - Keyboard Platform: 26.5" x 10.5"
 - Keyboard Platform includes palm rest
 - Palm rest can be positioned on the left or right side of the keyboard platform
 - Monitor can be rotated for viewing in landscape or portrait orientation
 - Monitor can be adjusted 12" vertically along the mount
 - Arm can be adjusted 19.5" up and down the pole

PART #	LIST PRICE
CLIMB1-SLV	\$773





HIPPA COMPLIANT
The TITAN2-EDGE
can be retrofitted
with the LOCKING
CPU to attain HIPPA
compliance.

TITAN SERIES PUBLIC ACCESS COMPUTER (PAC) STATION

- Keyboard Arm and Monitor Arm can be positioned anywhere along the wall track
- For left or right-handed users
- Keyboard tray folds up or down to save space
- Monitor weight range: 6.5 - 17.6 lbs
- Monitor arm Height Adjustment Range: 12.5"
- Monitor arm extension: 22.5"
- Keyboard arm extension: 23"
- Includes track covers to conceal cords



TITAN-EDGE SINGLE TRACK

- One 31.5" aluminum alloy wall track
- EDGE monitor arm (pg. 6)
- Keyboard platform

PART #	LIST PRICE
TITAN-EDGE	\$1,170



TITAN2-EDGE DUAL TRACK

- Two 31.5" aluminum alloy wall tracks (63" total)
- EDGE monitor arm (pg. 6)
- Keyboard platform
- PAC-CPUMINI CPU holder

PART #	LIST PRICE
TITAN2-EDGE	\$1,355

MINI CPU HOLDER

- Adjustable Width:
 - 3.25" - 6"
- Load Capacity:
 - 55 lbs
- Fits CPUs 5" to 20" in overall height



PART #	LIST PRICE
PAC-CPUMINI	\$97

LOCKING CPU

- Adjustable Width:
 - 3.5" - 9.3"
- Adjustable Height:
 - 12.5" - 22.5"
- Heavy duty tri-lobed shape knob with special hex key



PART #	LIST PRICE
PAC-CPULOCK	\$427



SECURITY

The LOCKING CPU provides added security where sensitive computer data is stored.





MOBILITY
 Make your technology mobile with a Workstation On Wheels

WOW SERIES
 WORKSTATION ON WHEELS

- Pneumatic lift platform with wire controller
- 5-star base with heavy-duty casters
 - 2 lockable
- Includes cable management system
- Platform measurement: 26.5" W x 22.5" D
- Platform height adjustment: 28"-41"
- Base measurement: 28" diameter
- Weight Capacity: 20 lbs



WOW
 COMPLETE WORKSTATION

Includes:

- Adjustable CPU Holder
- Palm rest
- Fixed monitor mount
- CPU Holder dimensions:
 - Adjustable height: 13" - 21"
 - Adjustable width: 2.5" - 8.25"

WOW01
 BASE MODEL

- Effortless height adjustment
- Ideal for mobile height adjustability
- Additional accessories available

PART #	LIST PRICE
WOW	\$1,368

PART #	LIST PRICE
WOW01	\$885



MONITOR MOUNT

- Fixed height
- Monitor Tilt: +25°/-90°
- 90° portrait/landscape adjustment
- 90° side-to-side rotation



PART #	LIST PRICE
WOW-MR	\$193

CPU HOLDER

- Adjustable CPU Holder for WOW
- Nonporous foam material prevents CPU damage
- Can be cleaned and sanitized to maintain a germ-free environment



PART #	LIST PRICE
WOW-CPU	\$231



CPUMINI

SMALL PROFILE

- 360° swivel
- 13.4" ball bearing glide track
- Adjustable width: 3.25" - 6"
- Adjustable height: 16" - 23"
- Load capacity: 55 lbs
- Fits CPUs 5" to 20" in overall height

PART # **CPUMINI** LIST PRICE **\$178**



CPU05

HEAVY DUTY

- 360° swivel
- 17.75" glide track
- Adjustable width: 2.5" - 8.25"
- Adjustable height: 13" - 21"
- Load capacity: 100 lbs

PART # **CPU05** LIST PRICE **\$207**



CPU01

SIMPLE

- 360° swivel
- 17.75" glide track
- Adjustable 60" straps
- Load capacity: 125 lbs
- Nylon security bands

PART # **CPU01** LIST PRICE **\$159**



CPUCART

MOBILE CART

- Fits CPU's ranging from 3.8"W - 9"W
- Load capacity: 160 lbs
- CPU sits in adjustable tray
- 4 swivel caster wheels (2 locking)
- Easy to assemble; no tools required to make adjustments

PART # **CPUCART-1** LIST PRICE **\$143**



CPU-TC

THIN CLIENT



- Mounts between the monitor arm and monitor (see right)
- Adjustable Width:
 - 1.375" - 2.25"
- Conforms to VESA 75mm/100mm
- Adjustment knobs are tamper and vibration resistant

PART # **CPU-TC** LIST PRICE **\$228**





DAISY CHAIN OPTIONS
Chain up to 7 LUCERA under cabinet lights!



LUCERA SERIES

UNDER CABINET LED LIGHT

- 2 lengths: 24", 36" (nominal)
- Color Temperature: 3500K
- Lumens: 24"=250 | 36"=420
- CRI: 85
- 24"= 6.3W | 36"=10.3W
- Lamp life: 50,000 hours
- Includes wood and magnet mounts
- Continuous dimming
- Daisy chain configurations include 24" jumper cord(s)
- 9' power cord

G2 SERIES

UNDER CABINET LED LIGHT

- 2 lengths: 24", 36" (nominal)
- Color Temperature: 3500K
- Lumens: 24"=550 | 36"=740
- CRI: 85
- 24"=11W | 36"=14W
- Lamp life: 50,000 hours
- Continuous dimmer
- Removable optical diffuser
- Daisy chain configurations include 24" jumper cord(s)
- Combination wood and magnet mount
- Light bar rotates 360°
- 9' power cord

FLUORESCENT SERIES

UNDER CABINET LIGHT

- The energy efficient T5 lamps emit minimal heat while providing optimal illumination.
- 2 lengths: 24", 48" (nominal)
 - Color Temperature: 3300K
 - Lumens: 24"=260 | 48"=759
 - 24"=13W | 48"=39W
 - Prismatic lens
 - Energy efficient T5 fluorescent lamp
 - Integrated magnet mounting system
 - Spring bars and wood screws included
 - 9' power cord with additional outlet for daisy chain configurations

PART #	LIST PRICE
● LUCERA-24-SLV	\$299
● LUCERA-36-SLV	\$411
OS-LUCERA OCCUPANCY SENSOR	\$122

OPTIONAL OCCUPANCY SENSOR

- Turns lamp off if no motion is detected for 15 minutes
- Resumes last brightness setting when motion is detected

PART #	LIST PRICE
● LEDG2-24-SLV	\$421
● LEDG2-36-SLV	\$519
LED-OS OCCUPANCY SENSOR	\$108

OPTIONAL OCCUPANCY SENSOR

- Turns lamp off if no motion is detected for 15 minutes
- Resumes last brightness setting when motion is detected

PART #	LIST PRICE
● UCL24MAG-BLK	\$187
● UCL48MAG-BLK	\$227

DAISY CHAIN CONFIGURATIONS

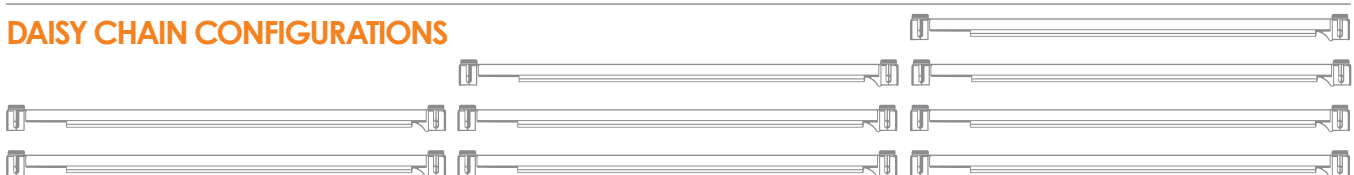

PART #	UNIT SIZE (EA.)	LIST PRICE	PART #	UNIT SIZE (EA.)	LIST PRICE	PART #	UNIT SIZE (EA.)	LIST PRICE
LEDG2-24X2-SLV	20" X 1" X 1.2"	\$837	LEDG2-24X3-SLV	20" X 1" X 1.2"	\$1,306	LEDG2-24X4-SLV	20" X 1" X 1.2"	\$1,641
LEDG2-36X2-SLV	25" X 1" X 1.2"	\$1,095	LEDG2-36X3-SLV	25" X 1" X 1.2"	\$1,604			
LUCERA-24X2-SLV	20.1" X .8" X .5"	\$599	LUCERA-24X3-SLV	20.1" X .8" X .5"	\$898	LUCERA-24X4-SLV	20.1" X .8" X .5"	\$1,291
LUCERA-36X2-SLV	31.7" X .8" X .5"	\$823	LUCERA-36X3-SLV	31.7" X .8" X .5"	\$1,233	LUCERA-36X4-SLV	31.7" X .8" X .5"	\$1,736

FOR MORE DAISY CHAIN CONFIGURATIONS, PLEASE VISIT OUR WEBSITE OR CONTACT CUSTOMER SERVICE FOR DETAILS.

- 1 PIXIE-LED
- 2 OMEGA-LX3
- 3 LUSTRE
- 4 VIVID-X
- 5 VIVID-LEX



PIXIE LED

- Small Footprint
- Color Temperature: 3000K
- Lumens: 250
- CRI: 80
- 3W
- Small profile
- Lightweight
- 11.8" reach
- Lamp life: 50,000 hours

PART #	LIST PRICE
PIXIE-LED-SLV	\$161

PIXIE LEDX

The PIXIE LEDX includes all features of the PIXIE LED model plus:

- Built-in dimmer
- 8 hour auto shut-off
- USB charging port

PART #	LIST PRICE
PIXIE-LEDX-SLV	\$202



VIVID-LEX

- Two arms
- Total reach: 36"



VIVID-X

- Single arm
- Total reach: 21"

VIVID SERIES

- Color Temperature: 3500K
- Lumens: 356
- CRI: 85
- 6W
- Lamp life: 50,000 hours
- 180° rotation at light source
- 360° rotation on base
- Built-in dimmer
- 8 hour auto shut-off

PART #	LIST PRICE
VIVID-X-SLV	\$362
VIVID-LEX-SLV	\$377
DC-V-SLV	DESK CLAMP \$71
GM-V-SLV	GROMMET MOUNT \$62
SLAT-V-SLV	SLAT MOUNT \$92



HANDS FREE
The LUSTRE includes an energy saving, Integrated Occupancy Sensor

Telescopes at two points

Single touch control

Includes USB charging port

LUSTRE

- Color Temperature: 3500K
- Lumens: 350
- CRI: 83
- 6W
- Lamp life: 50,000 hours
- 180° rotation at light source and lamp arm
- 360° rotation on base
- Cord length: 12'
- Telescoping arm and head
- Integrated Occupancy Sensor
- USB charging port

PART #		LIST PRICE
● LUSTRE-SLV		\$557
○ LUSTRE-WHT		\$557
● DC-LX3-SLV	DESK CLAMP	\$30
● GM-LX3-SLV	GROMMET MOUNT	\$56
● SLAT-LX3-SLV	SLAT MOUNT	\$47





OMEGA LX3

- Color Temperature: 3500K
- Lumens: 320
- CRI: 85
- 7W
- Lamp life: 50,000 hours
- Built-in touch strip with multiple dimming levels
- Two arms, 14.15" and 15" connected by a fully articulating joint
- Low profile: 7.5" base with 360° rotation
- Reach: over 20"
- C-UL-US Certified

Occupancy Sensor

Dimming Touch Strip

OCCUPANCY SENSOR

- Turns lamp off if no motion is detected for 15 minutes
- Automatically resumes last brightness setting
- Detects motion in a maximum range of 9.8 ft
- Compact - just .55"W x 1"H x .055"D

PART #		LIST PRICE
OMEGA-LX3		\$530
OMEGA-LX3-OS	OCCUPANCY SENSOR	\$107
OMEGA-LX3-DC	OMEGA LX3 + DESK CLAMP	\$560
OMEGA-LX3-GM	OMEGA LX3 + GROMMET MOUNT	\$586
OMEGA-LX3-SLAT	OMEGA LX3 + SLAT MOUNT	\$577



LEFTY OR RIGHTY
Platforms can be used by left or right-handed users.

THE BENEFITS OF A KEYBOARD PLATFORM

INCREASE DESKTOP REAL ESTATE

The ability to store the keyboard under the work surface provides the user with more desktop space on which to work.

IMPROVE WORKER COMFORT

Ergonomic keyboard platforms allow the user to set the height and angle of the keyboard tray to the person's ideal position, allowing posture change while enhancing comfort.

REDUCE REPETITIVE STRESS

If used properly, keyboard platforms keep wrists neutral, hands at the correct height and elbows open slightly beyond 90°.

All Combo Solutions include a keyboard platform, articulating arm, leatherette-covered gel palm rest(s), nonslip pads, mouse pad, mouse guards, and cord management clips at no extra charge. One part number is all you need for a complete system.



SOLUTION 1

VALUE ENGINEERED

PL003-25 KEYBOARD PLATFORM

- 25" rectangle platform
- Accommodates left or right-handed users
- Designed for straight-edge work surfaces

AA260 ARTICULATING ARM

- 17" glide track, spring assisted
- Height Adjustment Range: 6.25"
 - HIGH : 1.25" above track
 - LOW: 5" below track

PART #	LIST PRICE
SOLUTION 1	\$297



Available in R-Series. Call Customer Service for details.



SOLUTION 1CC

VALUE ENGINEERED

PL003CC-25 KEYBOARD PLATFORM

- 25" cut corner platform
- Accommodates left or right-handed users
- Designed for diagonal corner work surfaces

AA260 ARTICULATING ARM

- 17" glide track, spring assisted
- Height Adjustment Range: 6.25"
 - HIGH : 1.25" above track
 - LOW: 5" below track

PART #	LIST PRICE
SOLUTION 1CC	\$297



Available in R-Series. Call Customer Service for details.



SOLUTION 2

MOST POPULAR

PL003-25 KEYBOARD PLATFORM

- 25" rectangle platform
- Accommodates left or right-handed users
- Designed for straight-edge work surfaces

AA360 ARTICULATING ARM

- 21" glide track, Lift and Lock
- Height Adjustment Range: 7"
 - HIGH: 2.5" above track
 - LOW: 4.5" below track

PART #	LIST PRICE
SOLUTION 2	\$383



Available in R-Series. Call Customer Service for details.



SOLUTION 2CC

MOST POPULAR

PL003CC-25 KEYBOARD PLATFORM

- 25" cut corner platform
- Accommodates left or right-handed users
- Designed for diagonal corner work surfaces

AA360 ARTICULATING ARM

- 21" glide track, Lift and Lock
- Height Adjustment Range: 7"
 - HIGH: 2.5" above track
 - LOW: 4.5" below track

PART #	LIST PRICE
SOLUTION 2CC	\$383



Available in R-Series. Call Customer Service for details.

SOLUTION 3

UNIVERSAL FIT

PL215 SWIVEL MOUSE-BELOW PLATFORM

- 18.75" platform with left or right swivel below mousing platform
- Accommodates left or right-handed users
- Designed for radius corner work surfaces

AA360 ARTICULATING ARM

- 21" glide track, Lift and Lock
- 7" height adjustment (2.5" above to 4.5" below track)

PART # _____ LIST PRICE
SOLUTION 3 **\$429**

 Available in R-Series. Call Customer Service for details.



SOLUTION ULTRA

GREAT FOR MULTIPLE USERS

PL217 SWITCH-N-CLICK PLATFORM

- 18.75" keyboard platform and 9.25" Switch-n-Click mousing platform
- Recommended for straight-edge work surfaces

AA360 ARTICULATING ARM

- 21" glide track, Lift and Lock
- 7" height adjustment (2.5" above to 4.5" below track)

PART # _____ LIST PRICE
SOLUTION ULTRA **\$434**



SOLUTION 4

EXTENDED REACH



PLMAC MOUSE FORWARD PLATFORM

- Reversible 26.5" platform
- Accommodates left or right-handed users

AA370 EXTENDED REACH ARTICULATING ARM

- 24.75" glide track, Lift and Lock
- Height Adjustment Range: 16"
 - HIGH: 8" above track
 - LOW: 8" below track

PART # _____ LIST PRICE
SOLUTION 4 **\$477**

SOLUTION 7

POPULAR SPEC



PL217 SWITCH-N-CLICK PLATFORM

- 18.75" keyboard platform
- Reversible design; 9.25" mouse platform clicks in left or right side - no tools required
- Recommended for straight-edge work surfaces

AA750DAT ARTICULATING ARM

- 21.75" glide track, Lift and Lock
- Height Adjustment Range: 7.13"
 - HIGH: 2.25" above track
 - LOW: 4.88" below track
- Dial-a-Tilt gauge

PART # _____ LIST PRICE
SOLUTION 7 **\$450**

SOLUTION 6CC

INDUSTRY FAVORITE



PL003CC-27 KEYBOARD PLATFORM

- 27" cut corner platform
- Accommodates left or right-handed users
- Designed for diagonal corner work surfaces

AA750DAT ARTICULATING ARM

- 21.75" glide track, Lift and Lock
- Height Adjustment Range: 7.13"
 - HIGH: 2.25" above track
 - LOW: 4.88" below track
- Dial-a-Tilt gauge

PART # _____ LIST PRICE
SOLUTION 6CC **\$407**

 Available in R-Series. Call Customer Service for details.

SOLUTION ALL-FIT

FOR BENCHING AND TABLES



PL003-27N KEYBOARD PLATFORM

- 27" platform with notched cutout for additional retraction
- Designed for benching systems & tables where minimal track space is available

AA100 LIFT & LOCK ARTICULATING ARM

- Lift and Lock height adjustment
- +10°/-20° tilt adjustment and 360° rotation
- 12.75" glide track
- Height Adjustment Range: 6"
 - 2-3/8" above track | 3-5/8" below track
- Fully retracts on a 13" deep work surface

PART #	LIST PRICE
SOLUTION ALL-FIT	\$406

Available in R-Series. Call Customer Service for details.

PALM RESTS

Leatherette covered gel palm rests with threaded screw insert



PART #		LIST PRICE
ACRWMLG7-S	7" WIDE	\$53
ACRWMLG8-S	8" WIDE	\$53
ACRWMLG18-S	18" WIDE	\$72
ACRWMLG25-S	25" WIDE	\$73
ACMCLIPLG	PL217 MOUSING PLATFORM PALM REST	\$50



For more information and options, please visit our website at esiergo.com

SOLUTION 90

IDEAL FOR 90° CORNERS



PL003CC-25 KEYBOARD PLATFORM

- 25" cut corner platform
- Accommodates left or right-handed users
- Designed for 90° corners

AA355DS 7.5 SWIVEL ARTICULATING ARM

- 21.75" glide track, Lift and Lock
- Height Adjustment Range: 9.3"
 - HIGH: 3.42" above track
 - LOW: 5.88" below track
- Dual swivel adjustability

PART #	LIST PRICE
SOLUTION 90	\$559

Available in R-Series. Call Customer Service for details.

CORNER DIAGONAL

Converts 90° corners to diagonal corners for additional work area

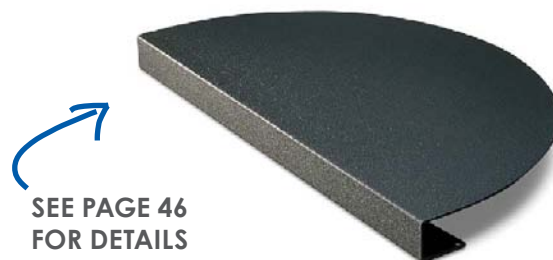

SPACERKIT

Ideal for Height adjustable tables and Benching systems, the SPACERKIT creates a flat mounting surface for keyboard arms and glide tracks where cross channels typically prevent installations.

- Compatible with all ESI keyboard arms and glide tracks
- Attaches between underside of worksurface and a keyboard arm or glide track
- Includes mounts for benching systems and Height adjustable tables
- Powder coated steel construction
- 2 sets of spacers included to accommodate needed spacing between 1" - 2.2"
- Includes installation hardware

PART #	LIST PRICE
SPACERKIT-KBD	\$62

48 HOUR SHIPPING

43

UNDERSTANDING KEYBOARD & MOUSING PLATFORMS

RECTANGLE

Designed for straight-edge work surfaces, Rectangle Platforms provide ample space for keyboard and mouse on the same level.

CUT CORNER

Designed for diagonal corners, Cut Corner Platforms are also well-suited for straight edge, and large radius work surfaces.

SWIVEL MOUSE

The space-saving Swivel Mouse design allows for keyboard storage where space is limited.

MOUSE FORWARD

Comfortably places the mousing area closer to the user for maximum ergonomic comfort.

RADIUS

Designed to complement radius corner work surfaces and position the keyboard closer to the work area.

NATURAL

Designed to accommodate Microsoft® Natural, Natural Elite, and other ergonomically designed keyboards.

PL003 RECTANGLE



- For use with straight edge work surfaces
- Accommodates left or right-handed users

PART #		LIST PRICE
PL003-19	19" WIDE	\$116
PL003-25	SHOWN	\$143
PL003-27	27" WIDE	\$151

 Available in R-Series. Call Customer Service for details.

PL003CC CUT CORNER



- For use with diagonal cut work surfaces
- Accommodates left or right-handed users

PART #		LIST PRICE
PL003CC-25	SHOWN	\$143
PL003CC-27	27" WIDE	\$151

 Available in R-Series. Call Customer Service for details.

PL215 SWIVEL MOUSE-BELOW PLATFORM



- Offers a universal fit on virtually any work surface shape
- Palm rest for both keying and mousing surface(s)
- 18.75" platform with a swivel-below mousing platform
- Accommodates left or right-handed users

PART #	LIST PRICE
PL215	\$189

PL006 RADIUS



- Designed for 42" and larger radius work surfaces
- Accommodates left or right-handed users

PART #	LIST PRICE
PL006-27	\$151

PL217 SWITCH-N-CLICK PLATFORM

- Reversible design; mouse platform clicks in left or right side - no tools required
- Independent tilt and swivel mousing platform
- Can be used as a mouse in line, mouse over, or mouse forward
- Recommended for straight-edge work surfaces

PART #	LIST PRICE
PL217	\$194
PL217NAT 	\$172



PALM REST

- 7"W x 2.5"D
- For use with the PL217 mouse platform

PART #	LIST PRICE
ACMCLIPLG	\$50



SWITCH-N-CLICK
Mouse platform can be used in 3 different positions.

PLMAC
MOUSE FORWARD PLATFORM



- Designed for straight-edge and 21" or larger diagonal work surfaces
- Accommodates left or right-handed users

PART #	LIST PRICE
PLMAC	\$155

PL005CC 
NATURAL CUT CORNER PLATFORM

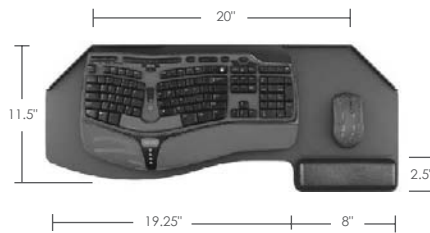

- Designed for use with Natural Keyboards
- Left-handed platforms available. Please call Customer Service for details.

PART #	LIST PRICE
PL005CC	\$129

PL200
SLIDE OUT MOUSE PLATFORM



- Left to right slide-out mouse tray
- 18.75" width while in closed position
- 27.75" width while in open position
- For left or right-handed users

PART #	LIST PRICE
PL200	\$224



AA260
SPRING ASSISTED

- Spring assisted height adjustment
- +10°/-15° tilt adjustment and 360° rotation
- 17" glide track
- Height Adjustment Range: 6.25"
 - 1.25" above track | 5" below track
- Soft touch knob for simultaneous height and tilt adjustment

PART #	LIST PRICE
AA260	\$154



AA330
LIFT & LOCK WITH SHORT TRACK

- Lift and Lock height adjustment
- +/-15° tilt adjustment and 360° rotation
- 17.75" glide track (platform may not fully retract in its stored position)
- Height Adjustment Range: 7"
 - 2.5" above track | 4.5" below track
- Positions platform flush with the work surface
- Release handle for independent tilt adjustment

PART #	LIST PRICE
AA330	\$240



AA360
LIFT & LOCK

- Lift and Lock height adjustment
- +/-15° tilt adjustment and 360° rotation
- 21" glide track
- Height Adjustment Range: 7"
 - 2.5" above track | 4.5" below track
- Positions platform flush with the work surface
- Release handle for independent tilt adjustment

PART #	LIST PRICE
AA360	\$240



AA370
LIFT & LOCK EXTENDED REACH

- Lift and Lock height adjustment
- +/-15° tilt adjustment and 360° rotation
- 24.75" glide track
- Height Adjustment Range: 16"
 - 8" above track | 8" below track
- Positions platform flush with the work surface
- Release handle for independent tilt adjustment

PART #	LIST PRICE
AA370	\$322



AA750DAT
LIFT & LOCK DIAL-A-TILT

- Lift and Lock height adjustment
- Dial-a-Tilt indicator gauge
- +10°/-15° tilt adjustment and 360° rotation
- 21.75" glide track
- Height Adjustment Range: 7.13"
 - 2.25" above track | 4.88" below track

PART #	LIST PRICE
AA750DAT	\$256



AA780DAT
LIFT & LOCK EXTENDED REACH

- Lift and Lock height adjustment
- Dial-a-Tilt indicator gauge
- +10°/-15° tilt adjustment and 360° rotation
- 21.75" glide track
- Height Adjustment Range: 12.93"
 - 8.25" above track | 4.68" below track

PART #	LIST PRICE
AA780DAT	\$379

The **UTILITY CART** is ideal for shared paper shredders and printers.



UTILITY CART ROLLING PLATFORM



- 18.75" X 15" platform
- Load Capacity: 150 lbs
- For printers, shredders, and other office machines
- Includes non slip pads
- 4 swivel caster wheels (2 locking)

PART #	LIST PRICE
ACPC-1	\$198

DESK RISERS TABLE BASE ACCESSORY



- Set of 4 stackable high-impact plastic risers
- Dimensions: 4" X 4"
- Raises work surface height in 1" increments
- Load Capacity: 600 lbs of distributed weight
- Limit of 3 risers per leg

PART #	LIST PRICE
DESK1	\$70

CONCEAL CABLE MANAGEMENT

The **CONCEAL** expands and retracts to keep cables organized under a height adjustable table base.

- Total Height: 53.5"
- Total # of links: 23
- Links are detachable
- Weighted bottom
- Attaches to bottom of work surface



PART #	LIST PRICE
● CONCEAL-GRY	\$61
● CONCEAL-BLK	\$61



CORNER DIAGONAL WORK SURFACE ACCESSORY

Converts 90° corners to diagonal corners for additional work area



- Includes spacers and felt furniture protectors
- Accommodates surfaces up to 1.375" thick

PART #	LIST PRICE
● ACCD90-17-BLK	FOR USE ON CORNERS LESS THAN 17" WIDE \$158
● ACCD90-21-BLK	FOR USE ON CORNERS LESS THAN 21" WIDE \$175

DRAWER SLIDE KEYBOARD TRAY



- 25" width accommodates both keyboard and mouse
- Retractable on 15" ball bearing slides

PART # AA903 LIST PRICE \$173

DRAWER SLIDE KEYBOARD DRAWER + SLIDE-OUT MOUSE PLATFORM



- Accommodates keyboard and slide-out left or right mousing area
- Retractable on 15" ball bearing slides

PART # AA904WM LIST PRICE \$121

PENCIL DRAWER WORK SURFACE ACCESSORY



- Inside drawer dimensions: 20.5"W X 16.25"D X 2" H
- Opening requirements: 23"W X 16.25"D X 2"H
- Retracts on 16" ball bearing slides

PART # ACPD01 LIST PRICE \$108



FOOTREST ADJUSTABLE FOOTREST

- Ideal for users who cannot rest their feet comfortably on the floor
- Dimensions: 15.75" L X 13.78" D X 2.76" H
- Anti-Slip rubber mat on top platform
- Four angle adjustments: 6° 12° 16° 25°
- Folds flat for easy height adjustment and storage

PART # FR301 LIST PRICE \$119

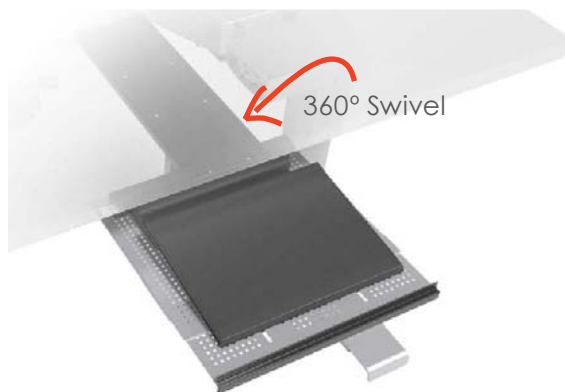

TECH DOCK SLIDING TECH TRAY

- Tech Dock is 15" in width and adjusts from 13.09" - 17.5" in depth
- Mounts underneath the work surface on a 18" glide track
- Fixed Mounting option without glide track

PART # TDOCK-SLV LIST PRICE \$129

- Rubber coated grip
- Convenient cable access
- Adjustable height of .72"
- Weight Capacity: 20lbs
- 100mm cooling fans can mount underneath the TECH DOCK for additional heat dissipation (hardware and fans not included)



The adjustable footrest includes 4 angle adjustments.

TERMS AND CONDITIONS

All prices shown are in US dollars. Contact Customer Service for a current Canadian Foreign Exchange Conversion Rate.

GSA Terms and Conditions may vary. Contact Customer Service or visit esiergo.com for more information.

PAYMENT AND CREDIT TERMS

To establish an account, Customer must submit completed ESI's new account application (signed by company officer), Federal Taxpayer ID (Form W-9) and State Resale Certificate. Once credit is approved, payment terms are net 30 days. Prior to Customer's credit approval (with receipt of required documents), prepayment of orders may be made by corporate check, or for your convenience, credit cards (VISA, Master Card and American Express) are accepted.

Past Due Accounts: Open orders or pending shipments will be held until account is brought current. ESI reserves the right to amend account terms, at any time, based on account history. Contact Accounting for details.

Deposits: Subject to sales and credit history, deposit may be required to process large orders.

PURCHASE ORDER SUBMISSION

Purchase Orders (POs) should be submitted via e-mail to orders@esiergo.com. POs should include "Ship To" and "Bill To" information along with complete ESI product part numbers and Customer cost. Incomplete POs or changes will delay processing and shipment pending receipt of all necessary information, ESI approval of order, and issuance of Sales Order Acknowledgement by ESI.

ORDER CHANGES OR CANCELLATIONS

All Customer cancellations and changes must be submitted to ESI in writing to orders@esiergo.com. Order changes include the addition/deletion of line items or changes in quantity or requested Ship Date or Ship To address. Order changes that result in a quantity reduction may be subject to an adjustment in pricing. Changes or cancellations after the Sales Order Acknowledgement is sent are subject to a 10% of Net fee. Change or cancellation requests are not considered accepted until ESI provides a revised Sales Order Acknowledgement. Changes will result in processing delays and scheduled shipments of at least 24 hours.

Under no circumstances will changes or cancellations be accepted on any order, special order, custom product, work surface order, or custom order specification without the express written consent of ESI. All such custom and special orders are non-cancellable and non-returnable.

TAXES

ESI is not responsible for collection of sales tax on products sold to dealers. Dealers must provide Federal Taxpayer ID (Form W-9) and State Resale Certificate to establish an account with ESI. Dealers are responsible for any sales or use taxes assessed if dealer requests that ESI dropship direct to dealers' customer.

PRICING

ESI reserves the right to revise all pricing, discounts, and freight terms, at any time, without notice. Current product pricing is included on product pages at esiergo.com. Prices which are in effect at time of order shall apply. Orders with requested ship dates of more than 90 days from receipt by ESI are subject to current/active pricing at shipment date.

SHIPPING

In general, orders from Customers with an open account in good credit standing are processed and shipped within 48 hours unless otherwise requested. Orders which include products designated as LLT (Longer Lead Time), custom products, table base/work surface orders or non-catalog items are not included in this policy. Large orders may also require additional lead time. ESI ships orders by way of standard ground carrier service dock-to-dock within the contiguous 48 states. Special requests such as "call before delivery", "delivery lift gate required", residential delivery or re-routed deliveries may not be available or may be subject to additional charges. Contact Customer Service for expedited delivery requests or deliveries outside of the contiguous 48 states.

Orders under \$100 Net will incur a \$14.99 flat shipping fee.

Table base orders for quantity of less than 20 normally ship in 48 hours. Standard laminate work surface orders for quantity of less than 20 normally ship in 10-14 business days. For lead times on all larger quantities of table bases/work surfaces please call Customer Service. Work surfaces may be drop-shipped from a separate location. Work surfaces are not sold separately and must be purchased with a table base. Orders for table bases, or table bases with work surfaces, totaling

under \$8,000 LIST will be charged a shipping fee equal to 8% of the total LIST price of table bases and work surfaces.

DELIVERY – DAMAGE /CLAIMS

ESI securely packages products to reduce risk of damage during shipment. ESI verifies order quantity and weight with carrier before any shipments are sent. When receiving an order, first confirm quantity of boxes delivered with carrier's quantity and inspect boxes for signs of damage. Carrier must record damages or shortages at time of delivery or claims will not be accepted. Do not sign for the shipment until it is verified. Signing a freight bill without any notation relieves the carrier of any responsibility and serves as your acknowledgement to ESI that shipment was received in full. Discrepancies or hidden damage found upon opening the shipment must be reported to ESI in writing within five (5) business days of delivery or Customer waives right to submit a claim. Damaged freight must not be removed from point of delivery and must remain in original packaging for inspection by carrier. ESI is not responsible for damages or discrepancies occurring after delivery. ESI reserves the right to request return of damaged or defective products.

RETURNS

Contact ESI Customer Service by e-mail (customerservice@esiergo.com) or phone (800.833.3746) to request a Return Authorization (RA) form. Please have the original PO number or ESI order number available. Request for product returns must be made to ESI within 60 days of the date shipped. Products, along with a copy of the RA form, must be received at ESI's Warehouse within 30 days of the date of the RA form issuance to be eligible for credit. Products received after this date will not receive credit. Custom products, non-catalog products, and work surfaces are non-returnable. Package(s) should be sent to:

**ESI Ergonomic Solutions
ATTN: Returns Department
4030 East Quenton Drive, Suite 101
Mesa, AZ 85215**

- Products returned to ESI without having been issued a RA or those not meeting the return requirements will not be eligible for credit.
- A re-stocking fee of 25% will apply to all non-warranty returns.
- To protect your return against loss, ESI recommends choosing a carrier who will provide tracking information and the ability to insure the shipment.
- Products which have been fully or partially assembled are not returnable for credit.
- Products must be returned in undamaged, re-sellable condition and in original packaging.
- Products should be carefully repacked to avoid damage during return shipping. Claims for product damaged on the return shipment are the responsibility of the Customer.

Upon receipt, the product will be inspected to ensure it meets ESI's return guidelines. Once approved, your account will be credited appropriately. No credit will be issued for unauthorized product returns or those not meeting return guidelines. Do not make any adjustments to your account until receipt of ESI Credit Memo. Costs associated with installation, return shipping, etc. of returned products will not be reimbursed. Please allow up to 30 days for returns processing.

WARRANTY

Complete warranty information is available upon request. ESI will repair or replace any product that is determined to be defective with the same or comparable product after inspection by an authorized ESI representative. Warranty shall apply to original purchaser only and request must be submitted with original PO number. Warranties are based on normal installation and use of products in a standard 8-hour shift. Warranty does not apply to damage in shipment caused by carriers, damage caused during installation, normal wear and tear, use or conditions. Products that are modified or tampered with in any way by any person other than an authorized ESI representative will not be covered under warranty. Costs (such as installation, labor fees or express shipping) incurred due to replacement of products will not be covered under warranty.

DISCONTINUED PRODUCTS

Due to changing market demands, ESI periodically may elect to discontinue certain products. ESI reserves the right to change and/or discontinue products at any time without notice.



FACTORY & SHOWROOM
4030 EAST QUENTON DRIVE
MESA, ARIZONA 85215

CHICAGO SHOWROOM
MERCHANDISE MART
SHOWROOM 10-100
CHICAGO, ILLINOIS 60654

P: 800.833.3746
info@esiergo.com
esiergo.com

GSA Contract Holder

WOMAN-OWNED
Business

© 2015 ESI Ergonomic Solutions
All rights reserved.